



SMT SERIES OPERATION AND MAINTENANCE MANUAL

akarasansor.com



CONTENT

1. General Information	3
1.1. SMT Series Motors	3
1.2. Structure of Operation and Maintenance Manual	3
1.3. User	3
1.4. Copyright.....	3
2. Safety Instructions.....	4
2.1. General	4
2.2. Technical Personnel Responsibility	4
2.3. Signs and Symbols Used in the Manual.....	4
2.4. Primary Safety Instructions	5
3. Condition of Product	6
3.1. Motor Weights.....	6
3.2. Operational Area	6
3.3. Transport and Handling.....	6
3.4. Intermediate Storage	7
3.5. Disposal / Recycling.....	7
4. Mechanical Installation	8
4.1. Mechanical Safety Precautions	8
4.2. Motor Mounting	8
4.3. Rope Protection Plate and Handles Adjustment	9
5. Electrical Connection	10
5.1. Electrical Safety Precautions.....	10
5.2. Motor Terminal Connection.....	10
5.3. Encoder Connection	12
5.4. Electromagnetic Brake Connection.....	12
6. Start-Up.....	14
6.1. Operating Conditions	14
6.2. Check List	14
6.3. EN 81-20 veEN 81-50 Motor Tests	15
6.3.1. Half Load Test	15
6.3.2. Checking of the Traction	15
6.3.3. Brake Tests	15

6.4. Emergency Operations	16
7. Faults and Remedy	18
8. Service and Maintenance	19
8.1. General Information on Service and Maintenance	19
8.2. Inspections	19
8.3. Encoder Mounting Instructions	20
8.3.1 ECN1313 Encoder	24
8.3.2 ERN1387 Encoder	24

1. General Information

1.1. SMT Series Motors

The SMT Series Motors are designed as gearless drive for rope system elevators with traction pulley. **No other drive applications are allowed without prior permission of AKAR.**

The SMT Series Motors are ideal for both roomless and machine room applications due to its compact design.

Thanks to its direct drive technology, the SMT Series Motors offer maximum travel comfort, minimum noise level, ease of installation and energy saving up to 40%. In addition to that, the SMT Series Motors are environment friendly since no oil is required for operation.

CE certificated AKAR® Electromagnetic Brakes provide maximum security. In addition, they are approved as a safety device for ascending car overspeed protection and unintended car movement (UCM).

1.2. Structure of Operation and Maintenance Manual

This manual is designed as a part of the motor and should be kept as a reference in order to be consulted when it is required. All personnels entrusted with the installation, operation, maintenance or repair of the drive must have read and understood manual completely and must comply with manual at all times.

AKAR takes no responsibility for damage or disruption caused by disregard of this manual.

In the interest of technical progress, AKAR reserves the right to make changes in the drive when it is necessary.

1.3. User

This manual addresses to the personnels involved in installation, operation, maintenance and repair services.

1.4. Copyright

The copyright for this manual is held by AkarAsansör Mot. Mak. San. Ltd. Şti. (Istanbul). Information in this manual is subject to change without any prior notice. No part of this manual may be reproduced or transmitted in any form or by any means, electronic or mechanical, for any purpose without the express written permission of AKAR.

2. Safety Instructions

2.1. General





The SMT Series Motors are not ready-to-use products for the end users. Prior to its operation; installation of the system with its necessary safety components, which may vary depending on the application, have to be completed. Systems reliability and system performance depend on the correct and safe installation of each component respectively.

2.2. Technical Personnel Responsibility

Installation, electric connections, operation, maintenance and repair services have to be performed by authorized and qualified technical personnel in conformity with the relevant standard and regulations.

2.3. Signs and Symbols Used in the Manual

The following signs and symbols are used throughout the manual in order to highlight hazardous areas as well as useful information and advice for users.

	DANGER! Severe injury may occur! Hazardous area. Death or severe injury may occur if the stated precautions are not taken.
	CAUTION! Material damage may occur! Material damage area. Significant material damage may occur if the stated precautions are not taken.
	DANGER! Electrical shock hazard! Dangerous electrical voltage area. Death or severe injury may occur if the stated precautions are not taken.
	INFORMATION Additional information for user.
	ADVICE Useful hints and advices for user.

2.4.Primary Safety Instructions

The motor is only to be used for specific purpose and elevator systems in which the producer was informed during order placement

The motor is only to be operated according to the specifications on the identification label.



The motor has a lifting ring. This ring has been designed to carry only the motor with its brake and sheave. Do not load any other components, e.g. ropes, sockets etc., on the motor.



The motor does not generate any torque when the motor current is cut off. In this situation, if the brakes are opened, the cabin will accelerate out of control. **Thus, it is highly recommended to short-circuit the motor windings during the installation of the elevator system.**



This will lead to the speed depending braking torque which is similar to the friction in traction machine-motor system. The short circuit has to be made by main contacts of the contactors. **Short-circuiting of the windings can only be made when the motor wires do not carry any current.**



Safety components which are monitoring brake releases, e.g. micro-switches, should not be demounted or deactivated.



The motor is only to be used with a screened power cable which also contains a grounding conductor. Please make sure that grounding of the screened power cable is performed separately from the grounding connection of the building.



U, V, W phase conductors of power cable should be connected in the same order of auto-tuning realization.

The SMT Series Motors are securely protected against overheating by the thermistors (PTC) installed into phase windings. Connections should be made through PTC controller. Max. 30V DC voltages can be applied to PTC. **Applying greater voltages may result in PTC damages and the motors will be no longer under warranty.**



The brake coils are designed based on the voltage specified on the brake label. The coils are protected against overvoltage by parallel connection of varistor.



Connection of brake micro-switches into the connection box is made through normally open (NO) contacts.



The motors will be no longer under warranty in case of any intervene to the red seals on the motors. Please get in contact with manufacturer if disassembly is required.



Encoder cable should be isolated from the electromagnetic effect caused by main supply cable. Otherwise, inverter errors and travel discomfort may occur due to the stray current.

3. Condition of Product

3.1. Motor Weights

Motor weights are stated on the identification label. Use suitable lifting equipment, taking into account the weight of the motor.

3.2. Operational Area

The SMT Series Motors are ideal for both roomless and machine room applications due to its compact design.

Operational area in which the motor is installed into should satisfy the following conditions,

- ✓ Ambient temperature must be between 0 °C and 40 °C.
- ✓ Humidity ratio should be less than 95% and the environment should not be wet.
- ✓ The protection class written on the label value should be checked.
- ✓ Protective measures should be taken against building wastes and external influences (water, moisture, dust, etc.)



If the operational area is different from the specified environments, contact the manufacturer.

3.3. Transport and Handling

The transportation of SMT series motors is carried out as agreed with the shipping company.

There is a lifting ring on the motor. The ring is designed to carry **only** the motor, brakes and pulley.

- ✓ Carry the engine in its original package with the help of a pallet truck or forklift and after opening the package use the lifting ring.
- ✓ Use suitable lifting equipment, taking into account the weight of the engine. Engine weights are stated on the motor identification label.
- ✓ Take precautions to prevent shocks and vibrations that may occur during transportation.



Do not load external loads (eg ropes, sockets, etc.)



Consider the center of gravity during transport.



Check the packaging for possible damages and losses, if necessary, contact the shipping company. Damage and losses during transportation are not covered by the warranty.

3.4. Intermediate Storage

In cases where stocking is required,

- ✓ Store the motors in their original packaging in a dry area.
- ✓ Take precautions against extreme weather conditions.
(Recommended storage conditions: -20 ° C to 60 ° C)
- ✓ Take protective measures against external factors (water, moisture, dust, etc.) and building wastes.
- ✓ Avoid long-term stocking.
(Recommended maximum stocking period: 1 year)



If unusual noise is observed during start-up, contact the manufacturer.

3.5. Disposal / Recycling



It should be carried out in a professional and environmentally friendly manner in accordance with legal regulations.

4. Mechanical Installation

4.1. Mechanical Safety Precautions

Mechanical installation should only be done by authorized and trained personnel.

During the installation, compliance with the standards is the responsibility of the contracted company.

If you encounter any problems, please contact the manufacturer. (Contact information can be found on the back of this manual and on motor identification label.)

- ✓ Before the motor installation, check the motor for possible damages and losses that may occur during transportation.



There is a lifting ring on the motor. The ring is designed to carry **only** the motor, brakes and pulley. Do not load external loads (eg ropes, sockets, etc.)

- ✓ **Do not apply any force to the motor, brake or pulleys.**
- ✓ The motor and especially the brakes must be protected against moisture, water, dust and building waste.
- ✓ Air flow around the motor should not be obstructed in any way. Otherwise it will cause the engine to overheat.



Allow at least 150 mm (horizontally) distance between the brake and the wall for easy access to the encoder.



Brake assemblies on SMT series motors and brake settings are made by Akar. **Please do not make any adjustments!**Otherwise, the motor and brakes will be out of warranty.

Brake replacement must be within the knowledge of Akar. If brake replacement is required, contact the manufacturer.



Do not do any welding work on the motor! Magnet and bearings can be damaged.In case of any violation; the motor will be out of warranty.



In case of any intervention to the motor, brake and accessories; the motor is out of warranty.

4.2. Motor Mounting

SMT series motors have mounting holes in the base of the motor body.

- SMT 120AC-08/12** type motors must be fixed to the mounting surface with four M12 (Quality 8.8) bolts. (Apply 86Nm torque)
- SMT 140AC-10/15/20** type motors must be fixed to the mounting surface with four M16 (Quality 8.8) bolts. (Apply 195Nm torque)
- SMT 200AC-15/17/20** type motors must be fixed to the mounting surface with four M20 (Quality 8.8) bolts. (Apply 395Nm torque)
- SMT 225AC-20/30** type motors must be fixed to the mounting surface with four M24 (Quality 8.8) bolts. (Apply 680Nm torque)
- SMT 250AC-30/40/50** type motors must be fixed to the mounting surface with six M24 (Quality 8.8) bolts. (Apply 680Nm torque)
- Tighten diagonally and apply the same force to each bolt.
- The flatness of the mounting surface should be max. 0,3mm.

- h. Mounting surface must be resistant to the forces to be applied.
- i. Use vibration damping pads to absorb vibrations that may occur.

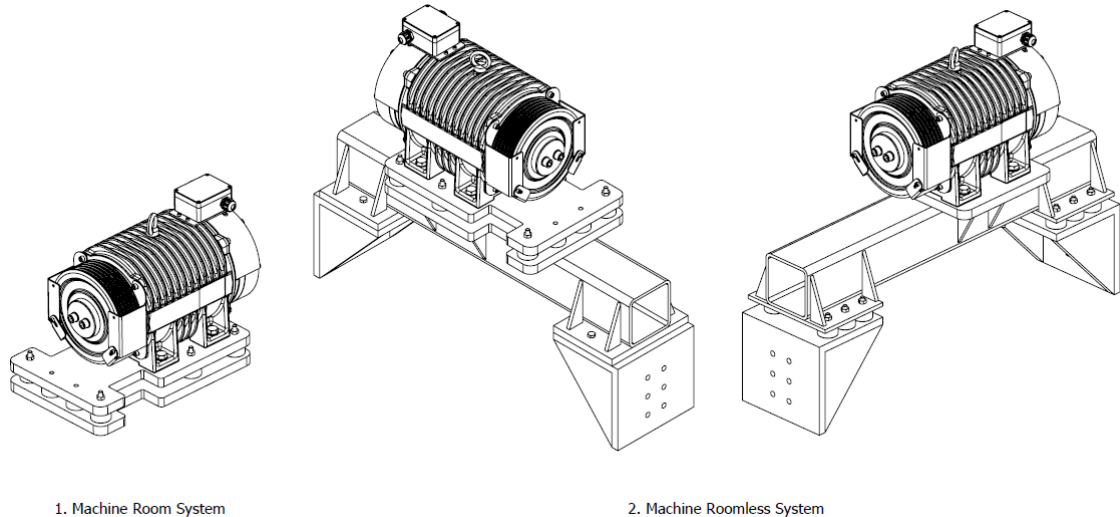

Figure 1 - Sample Motor Mounting

4.3. Rope Protection Plate and Handles Adjustment

SMT series motors are delivered as the rope protection plate and handles are mounted on.

- ✓ Rope protection plate and handles are fixed on the motor front cover. (Wrapping angle is considered as 180°.)
- ✓ During installation, you may need to remove the rope protection plate and handles. However, when the installation is finished, do not forget to securely reassemble them, taking into account the wrapping angle.
- ✓ The distance of the rope protection handles and the ropes should be at least 3mm.
- ✓ No need for further adjustments other than the ones stated above.

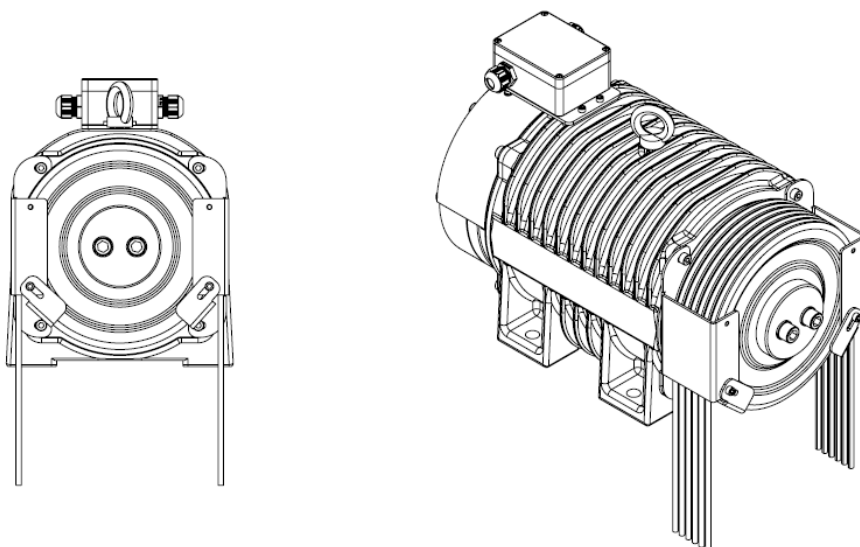

Figure 2 - Rope Protection Plate and Handles

5. Electrical Connection

5.1. Electrical Safety Precautions

Electrical connections should only be made by authorized and trained personnel. Compliance of the installation with the standards is under the responsibility of the contracted company.

If you encounter any problems, please contact the manufacturer. (Contact information can be found on the back of this manual and on motor identification label.)

Before installing the motor, make sure that the cables are not damaged during transportation.

5.2. Motor Terminal Connection

An inverter and an encoder are required for SMT series motors to operate.

- ✓ Make the motor and brake connections according to the terminal connection diagram. (Figure-3/4)
- ✓ Unless specified otherwise, encoder offset should be set to 0. To do this, supply DC voltage to U phase (+) and V & W phases (-).
- ✓ U, V, W phases should be connected to the terminal box in the correct order in order to perform the auto-tuning process properly. **Otherwise, the motor may accelerate uncontrollably.**
- ✓ **Check the grounding connection and make sure it is made properly.**
- ✓ The motor must be used only with a shielded power cable with grounding. Please make sure the

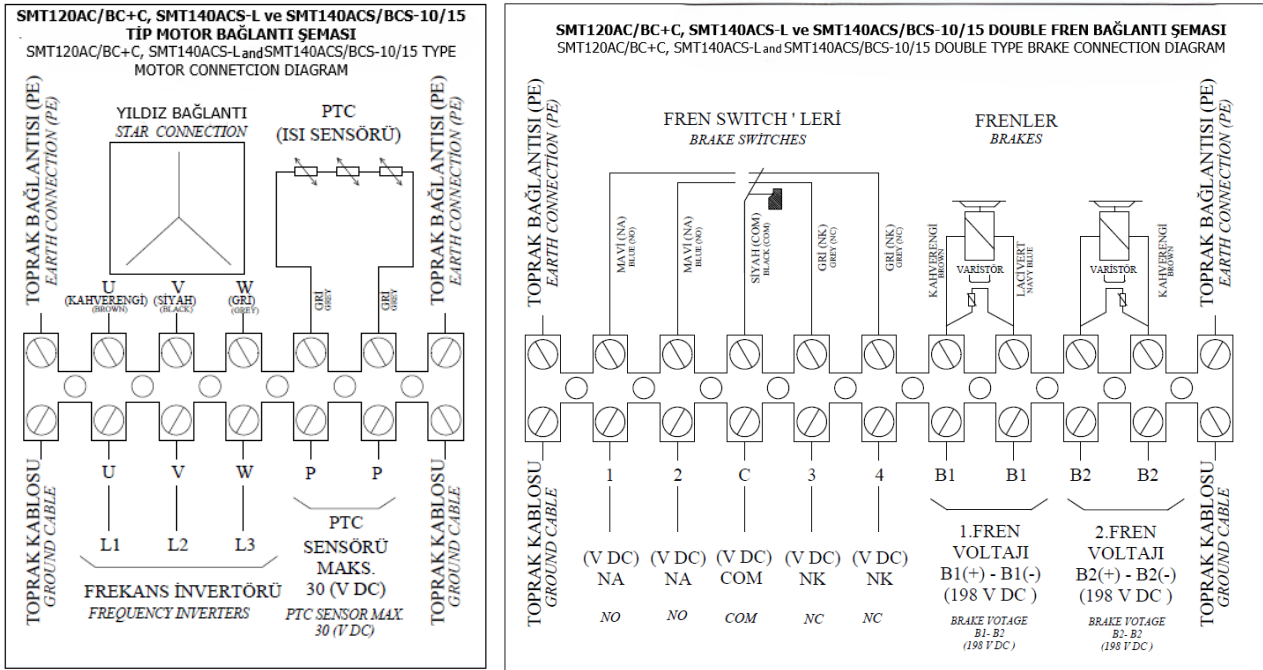

Figure 3 - SMT120AC/BC, SMT140ACS-L and SMT140ACS/BCS-10/15 Type Terminal Connection Diagram

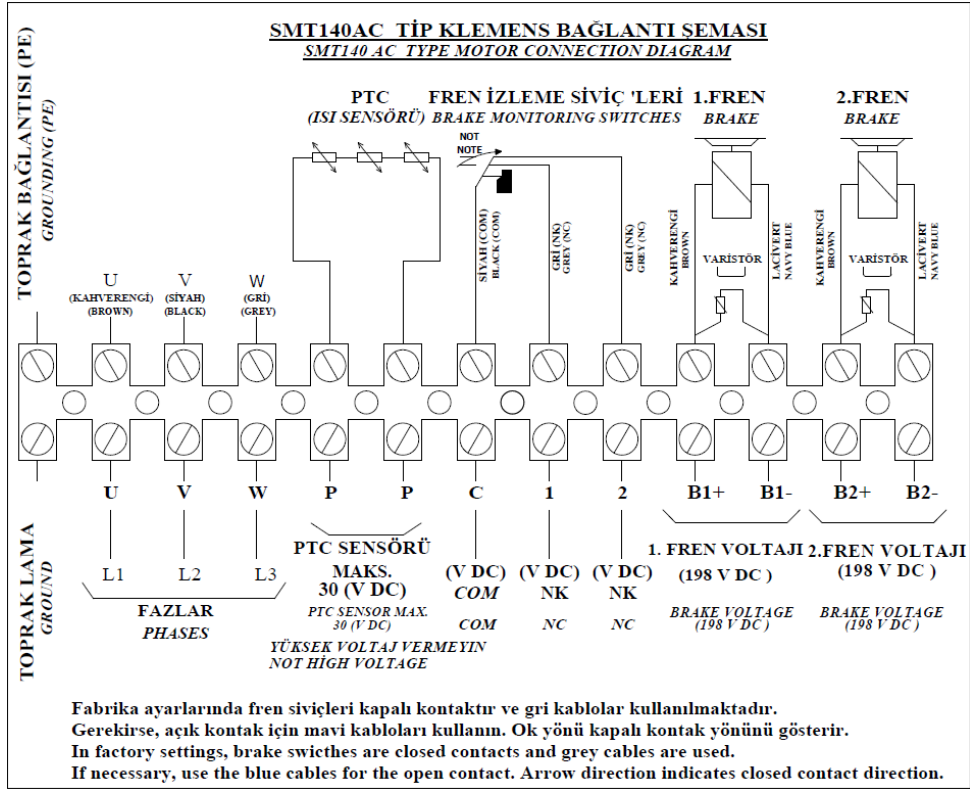

Figure 4 - SMT140AC Type Terminal Connection Diagram

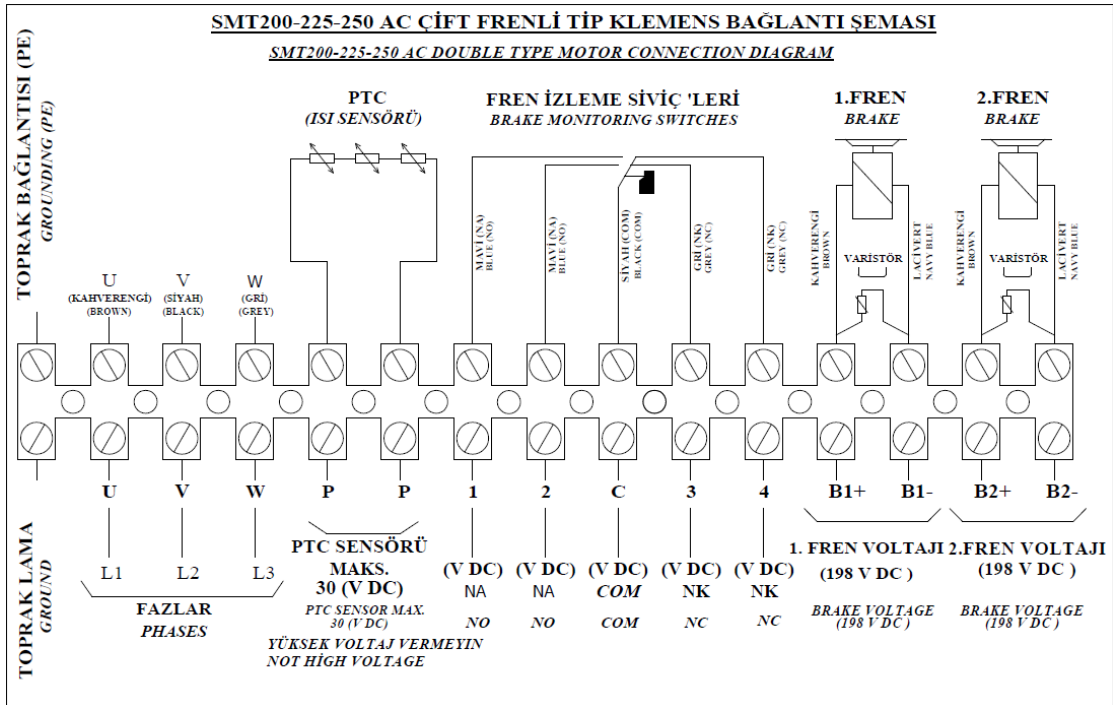

Figure 5 - SMT200AC – SMT225AC – SMT250AC Type Terminal Connection Diagrams



SMT series motors are protected by PTC thermistors connected to phase windings against overheating. Connections must be made through the PTC controller and a maximum of 30V DC must be applied. **Higher voltage values damage the PTC and the motor is out of warranty.**

5.3. Encoder Connection

In SMT series motors, the encoder is mounted on the main shaft by the manufacturer.

- ✓ The encoder is supplied with a 7 meter shielded cable.
- ✓ **The encoder must be compatible with the software of the inverter.**



The factory settings were made by AKAR during the auto-tuning process. **Please do not try to make other settings and do not remove the encoder!**



The replacement of the encoder should only be done by authorized and trained personnel. If replacement is required, the encoder must be re-introduced to the inverter.



In order not to cause measurement errors, protect the encoder against mechanical impacts.

Do not touch the encoder and encoder cable directly. The encoder is sensitive to electrostatic discharges and may deteriorate as a result of discharge.

5.4. Electromagnetic Brake Connection

Electromagnetic brakes are mounted on SMT series motors by the manufacturer. Brake settings are made by AKAR. You do not need to make any further adjustments.



Please do not try to make any brake adjustments! Otherwise, the brakes and motor will be out of warranty.

Brake replacement should only be done with AKAR support. If brake replacement is required, contact the manufacturer.

- ✓ Electromagnetic brakes are designed for static brake applications. In static brake applications, wear of brake linings is at minimum level. For this reason, brakes generally do not require maintenance.
- ✓ Dynamic applications are limited to brake tests and emergency braking which are only performed by the manufacturer.
- ✓ In case of power failure, it is not possible to open the brakes manually or mechanically. Brakes can be released by the auxiliary power supply (UPS, Battery etc.).
- ✓ Brakes are protected against switching high voltages. Terminal connections of varistors are made by AKAR.



Brake release control should be done via microswitch. Otherwise, the brake will be out of warranty.



Microswitches are used to monitor the instant status of the brakes. According to the signal coming from the microswitches, the inverter decides whether the system should work or not.

If the brake is released successfully, the inverter allows the system to run. Otherwise, the inverter will stop the system. Thus, the motor does not draw too much current from the system to overcome the braking torque. As a result, the motor and inverter are protected against high voltage.

It is recommended to use two contactors (AC side and DC side) for brake switching. During normal operation the contactor on the AC side must be switched by the brake relay. In this way, the mechanical noise that may occur is reduced.



On the other hand, the contactor on the DC side must be switched by the motor contacts. In this way, it ensures that the brake responds quickly to the signal and closes quickly in emergency situations.



Do not connect the motor directly to the main supply without the inverter!



Standard brake voltage is 198V DC. Applying a voltage lower than the operating voltage to the brake coil ends will cause the brake to fail to fulfill its function properly. In this case, the brake may sound rubbing, the motor may draw excessive current, the motor may overheat or the drive may fail. Applying a higher voltage than the operating voltage will cause the brake to heat up quickly.

6. Start-Up

6.1. Operating Conditions

The operating area where the motor is installed must meet the following conditions,

- ✓ Ambient temperature must be between 0 °C and 40 °C.
- ✓ Humidity ratio should be less than 95% and the environment should not be wet.
- ✓ The protection class written on the label value should be checked.
- ✓ Protective measures should be taken against building wastes and external influences (water, moisture, dust, etc.)



Motor should not be operated in environments where explosive gas exists.



If the working conditions are different from the specified environments, contact the manufacturer.

6.2. Check List

Make sure to provide the following items before starting the motor:

- ✓ Insulation and operating conditions should be similar to label values and this manual (See previous pages).
- ✓ Engine operating conditions should be similar to label values.
- ✓ Brake voltage supply must be similar to brake label values.
- ✓ Mechanical and electrical connections should be adjusted according to this manual.
- ✓ Make sure the fixing bolts are installed properly.
- ✓ Make sure that the motor is fixed on the horizontal platform in a balanced and parallel manner.
- ✓ Check that the direction of rotation of the motor is correct.
- ✓ Make sure the load is evenly distributed between the ropes.
- ✓ Make sure the air-flow around the motor is not blocked.
- ✓ Make sure the safety components are properly installed.
- ✓ Make sure the motor windings are short circuited.
- ✓ Check that the electrical insulation resistance is sufficient.
- ✓ Check if the grounding connection is done correctly.
- ✓ Check that the PTC thermistor is supply with max. 30V DC.
- ✓ Make sure that necessary precautions are taken for all parts moving under electrical voltage.
- ✓ Make sure that all cable entries are covered.
- ✓ Observe that the engine runs quietly and without vibration.



Please be aware that the list above does not cover every possible situation. Additional tests and controls may be required. Therefore; **start-up and commissioning must be carried out by authorized and experienced personnel who have knowledge and experience in this regard.**

6.3. EN 81-20 veEN 81-50 Motor Tests



Make sure the motor is not short circuited before starting the test. Thus, only the braking effect can be tested without motor interference.



It is recommended that tests be conducted when the car is at half the height of the the travel distance.

6.3.1. Half Load Test

The two current values have to be measured in the middle of the travel distance while the car loaded with 50% of the rated load is travelling upwards and downwards. The deviation between two currents should be max. 10%.

6.3.2. Checking of the Traction

In accordance with EN81 6.3.3 Checking of the traction (5.5.3);
The traction shall be checked by making several stops with the most severe braking compatible with the installation. At each test, complete stoppage of the car shall occur.

The test shall be carried out:

- a) ascending, with the car empty, in the upper part of the travel;
- b) descending, with the car loaded with 125 % of the rated load, in the lower part of the travel;

The counterweight shall be brought into contact with the buffer(s) and the machine shall continue to be turned until rope slippage occurs, or if slippage does not occur the car shall not be raised. It shall be checked that the balance is as stated by the installer.

6.3.3. Brake Tests

a) Overload Test

The test is conducted when the car is travelling downwards at rated speed and with the rated load plus 25 %. Motor and brake power must be cut off. In these conditions the retardation of the car shall not exceed that resulting from operation of the safety gear or stopping on the buffer.

b) One Brake Failure Test

For dual brake systems; test should be done with a single brake at rated speed and rated load written on the label values. Motor and brake power must be cut off.

WARNING 1: During one brake failure test; one of the brakes must be released, the other must be operated and tested separately.

WARNING 2: While the test is taking place; the elevator system should be carefully observed. If the car does not slow down, the other brake should be activated immediately.

c) Micro-Switch Test

The microswitch should be tested on its own, separate from the brake. According to the use of normally open or normally closed contacts, one microswitch contact must be opened or closed at a time. If there is an incorrect or missing microswitch signal, the motor should not be put into service.

6.4. Emergency Operations

In emergencies, operation should only be carried out by authorized and trained personnel.



In permanent magnet synchronous motors, upward movement causes difficulty at values where the nominal load exceeds 400N. Therefore, the electrical operation in the event of an emergency should be adapted to the requirements of 5.12.1.6 (EN 81-20 clause 5.9.2.3.3).

a) Emergency Electrical Operation

Emergency operation must comply with the requirements for emergency electrical operation (above) and the means to activate the emergency operation must be placed in one of the following:

- the machine room (5.2.6.3);
- the machinery cabinet (5.2.6.5.1); or
- on the emergency and tests panel(s) (5.2.6.6)

It must also meet the requirements of 5.12.1.6:

a) operation of the emergency electrical operation switch shall permit the control of car movement by constant pressure on buttons protected against accidental operation. The direction of movement shall be clearly indicated;

b) after operation of the emergency electrical operation switch, all movement of the car except that controlled by this switch shall be prevented;

c) the effects of the emergency electrical operation shall be overridden by switching on the inspection operation as follows:

1) when actuating the emergency electrical operation switch whilst the inspection operation is actuated, the emergency electrical operation is inactive, the up-/down-/run buttons of the inspection operation shall remain effective;

2) when actuating the inspection operation whilst the emergency electrical operation is actuated, the emergency electrical operation becomes inactive, the up-/down-/run buttons of the inspection operation shall become effective.

d) the emergency electrical operation switch shall render inoperative by itself or through another electric switch in conformity with 5.11.2 the following electric devices:

- 1) those used for checking slack rope or chain according to 5.5.5.3 b);
- 2) those mounted on the car safety gear, according to 5.6.2.1.5;
- 3) those for overspeed, according to 5.6.2.2.1.6 a) and b);
- 4) those mounted on the ascending car overspeed protection means, according to 5.6.6.5;

- 5) those mounted on the buffers, according to 5.8.2.2.4;
- 6) final limit switches, according to 5.12.2;
- e) the emergency electrical operation switch and its push-buttons shall be so placed that the machine can be observed directly or by display devices (5.2.6.6.2 c);
- f) the car speed shall not exceed 0,30 m/s.



It is recommended to use an uninterruptible power supply (UPS) or battery for emergency operation.

b) Emergency Mechanical Operation

Emergency mechanical operation should be used if and only if there are no other options for rescue. (when the brake is burnt, etc.)

It is highly recommended to short circuit the winding ends of the motor to prevent uncontrolled acceleration of the car.



In this case, the speed will depend on the brake torque, similar to the pulley friction in machine-motor systems. **Short circuit should be done from the contactor ends of the main contacts. Short-circuiting the windings can only be done when no current flows through the windings.**

Emergency mechanical operation should be implemented by authorized and trained personnel, following the following safety instructions:

- ✓ Emergency mechanical operation should be done with the use of brake release apparatus.
- ✓ Make sure that the motor winding ends are short-circuited. (Short circuit is important for the motor shaft not to be released. Otherwise, motor will accelerate uncontrollably in the direction of the heavy side of the system as a result of the motor shaft being released.)
- ✓ In this way, the car will move at a constant speed depending on the brake torque in the direction of the heavy side of the system.
- ✓ Close the brake when you want to stop the system.
- ✓ Brake release apparatus should be stored in a safe place and out of the reach of unauthorized persons.



Brake release apparatus is an option and AKAR is in no way responsible for improper use of it.

c) Power Failure Operation

In cases where power failure occurs and the cabin cannot reach the floor level, it is applied to bring the cabin to the appropriate floor level and to provide evacuation. This work should be done with an uninterruptible power supply (UPS).



Power failure operation and emergency operation operations are implemented separately and are not interchangeable.

7. Faults and Remedy

	Failure	Possible Reason	Recommendation
1	There is leakage electricity in the motor body	No grounding process	Ground wire must be connected to the motor housing.
2	Motor does not rotate	Brake does not open	See Failure5 “Brake does not open” in the table.
		Phase ends are incorrectly connected	Check the U, V, W terminals connected to the motor terminal.
		False signal from microswitch	Microswitch adjustment should be done.
3	Motor draws too much current	Brake does not fully pull	See Failure5 “Brake does not open” in the table.
		Phase ends are incorrectly connected	Check the U, V, W terminals connected to the motor terminal.
		Counterweight not in balance	When the cabin is loaded with semi load and the elevator is directed to the lowest floor and to the top floor; the currents in the ups and downs are monitored from the driver's screen. The currents drawn when passing through the midpoint of the elevator shaft should be close to each other.
4	Motor makes noise while running	Brake does not fully pull	See Failure5 “Brake does not open” in the table.
		VVVF driver settings incorrect	Check VVVF driver settings.
5	Brake does not open	Low brake supply voltage	Supply voltage must be increased to the voltage level specified on the brake label.
		Brake coil is burnt out	Please contact our company.
		Working clearance between brake mirror and brake body is out of allowable range (max.0,6mm)	Please contact our company.
6	Braking does not occur	Voltage is applied during the closing of the brakes	Check the power supply and microswitch settings.
7	Unstable braking	Low brake supply voltage	Supply voltage must be increased to the voltage level specified on the brake label.
		False signal from microswitch	Microswitch adjustment should be done.
8	Noisy braking	VVVF driver settings incorrect	Check VVVF driver settings (parameters related to the moment of stopping).
		Switching from DC part in normal operation	Check 5.4 <i>Electromagnetic Brake Connection</i> section of the manual and perform AC switching.
		The brake air gap is more than it should be (max. 0,6)	Please contact our company.

8. Service and Maintenance

8.1. General Information on Service and Maintenance

Service and Maintenance services should only be carried out by authorized and trained personnel.

- ✓ Track unusual noises when working or braking of motor.
- ✓ Always follow the safety instructions.
- ✓ Consider that the UPS may be defective in emergency operation. For this reason, service personnel should have a substitute UPS with them.
- ✓ Electromagnetic brake adjustment is not allowed. If the working distance between the brake body and the mirror exceeds the maximum value given, please contact the manufacturer.



Motor disassembly is not allowed. **Beware of the strong magnetic force!**



There is no need for any lubrication process in SMT series motors. **Please do not lubricate the bearings.**

8.2. Inspections

Type of Maintenance	During Commissioning	Inspection Interval
Distance between rope and rope protection	YES	Every 4 months
Power supply (UPS) functionality test	YES	Monthly
Check machine body bolts – if necessary tighten	YES	Monthly
Traction pulley control	YES	Monthly
Brake functionality test	YES	Monthly
Traction pulley protection control	-	Yearly
Clearance between the brake body and the mirror	-	Yearly

8.3. Encoder Mounting Instructions

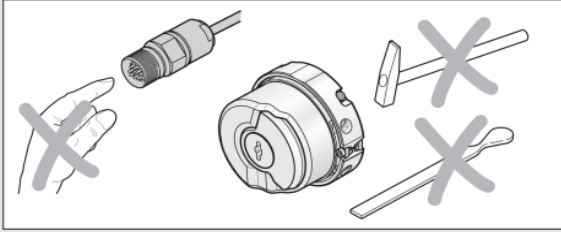
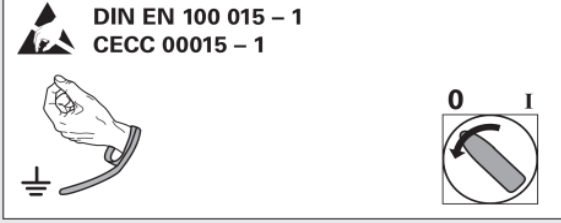

Paket dâhilinde
Included in delivery

M5x50 DIN 6912 8.8
ID 202 264-36

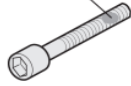

HEIDENHAIN

Montaj Talimatları
Mounting Instructions

ECN 1313 EnDat01

9/2005

DR. JOHANNES HEIDENHAIN GmbH

Dr.-Johannes-Heidenhain-Straße 5

83301 Traunreut, Germany

+49 (86 69) 31-0

+49 (86 69) 50 61

E-Mail: info@heidenhain.de

Technical support +49 (86 69) 32-10 00

Measuring systems +49 (86 69) 31-31 04

E-Mail: service.ms-support@heidenhain.de

TNC support +49 (86 69) 31-31 01

E-Mail: service.nc-support@heidenhain.de

NC programming +49 (86 69) 31-31 03

E-Mail: service.nc-pgm@heidenhain.de

PLC programming +49 (86 69) 31-31 02

E-Mail: service.plc@heidenhain.de

Lathe controls +49 (86 69) 31-31 05

E-Mail: service.lathe-support@heidenhain.de

www.heidenhain.de



Ve 00

533 396-91 · 60 · 5/2007 ·

Değişim hakkı saklıdır · Subject to change without notice ·

ECN 1313/EQN 1325 EnDat01

Ölçüler mm birimindedir

Dimensions in mm

A = Rulman
Bearing

K = Gerekli eşleştirme ölçüleri
Required mating dimensions

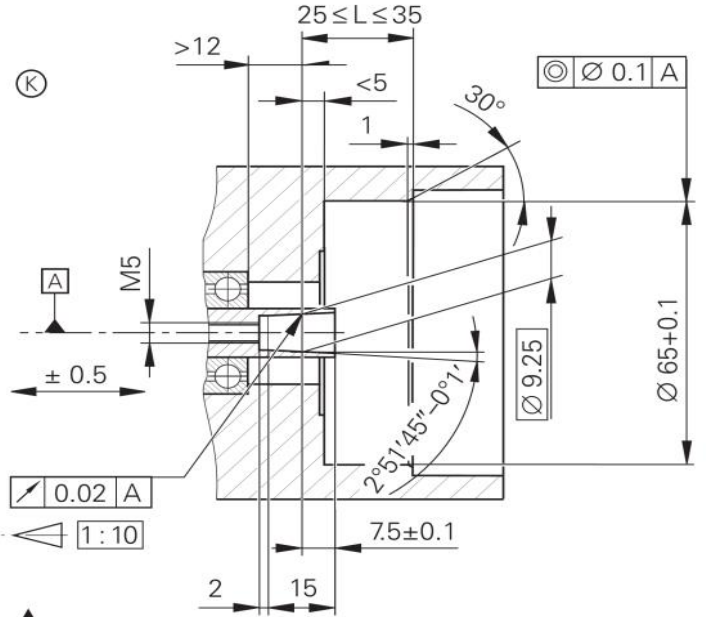

SW3/SW4

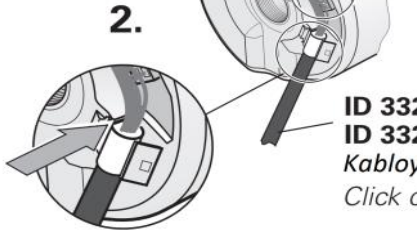

ID 332 201-xx
ID 332 202-xx

Kabloyu şekildeki gibi bastırarak yerine yerleştirin

Click cable into place, and push it in as far as possible

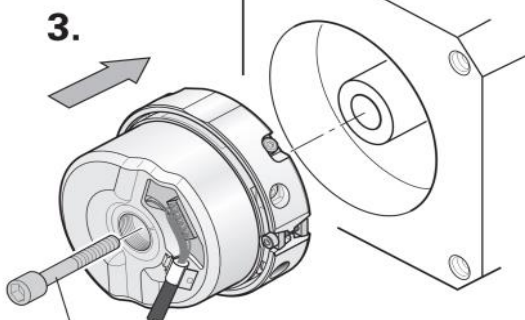

M5x50 DIN 6912 8.8

SW4

M_d = 5 + 0.5 Nm

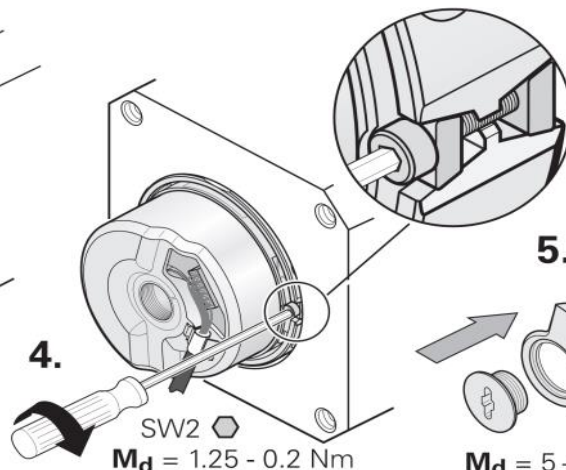

SW2

M_d = 1.25 - 0.2 Nm

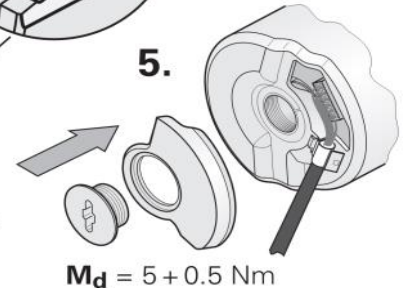

M_d = 5 + 0.5 Nm

Demontaj için sıralamayı tersten uygulayınız
Disassembly in reverse order

Demontaj sırasında enkoderi çıkarmanın iki farklı yolu
Two ways of pressing the encoder out during dismounting

a)

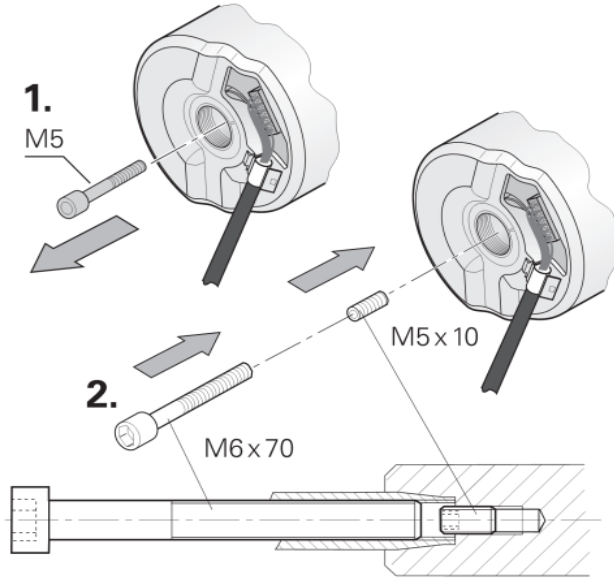

b)

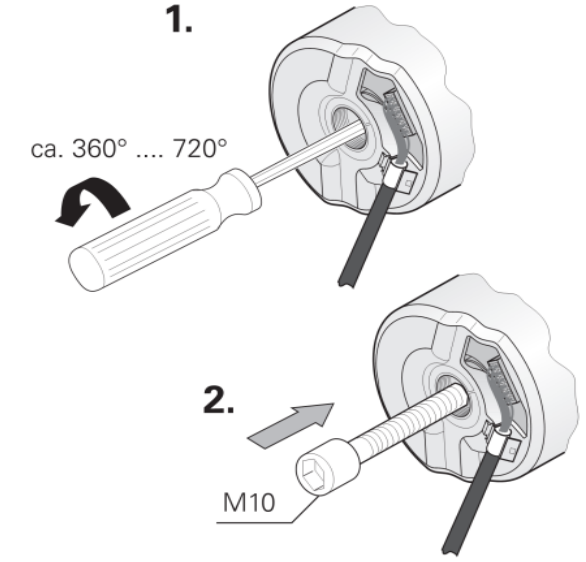

RS-485

CLOCK
CLOCK

$U_p = 5V \pm 5\%$
ECN 1313: (max. 160 mA)
EQN 1325: (max. 200 mA)
Enkoder , at encoder

EN 50 178/4.98; 5.2.9.5
IEC 364-4-41: 1992; 411(PELV/SELV)
(see
HEIDENHAIN D 231 929)

RS-485

DATA
DATA

A
B

360° el.
90° el.
0.8 ... 1.2 V_{SS}
(≈ 1 V_{SS})

Başlangıç pozisyonu için mil/başlık ayarı
Zero position for shaft/cap alignment

L [m]

fc [kHz]

$f_c = \frac{1}{T}$

Parazit kaynakları
Noise sources

			 °C (°F)	 T ≥ -40 °C (-40 °F)	 T ≥ -10 °C (14 °F)
Ø 4.5 mm 	R ₁ ≥ 18 mm R ₁ ≥ 40 mm	/ R ₂ ≥ 100 mm		 -30 ... 80 °C (-22 ... 176 °F)	

8.3.1 ECN1313 Encoder



62S12-78

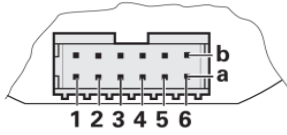

Ekran bağlantısını unutmayınız!

Do not forget shielding!

1b	6a	4b	3a	2a	5b	4a	3b	6b	1a	2b	5a
5V U _P	5V Sensor	0V U _N	0V Sensor	A+	A-	B+	B-	DATA	$\overline{\text{DATA}}$	CLOCK	$\overline{\text{CLOCK}}$
Kahve / Yeşil	Mavi	Beyaz / Yeşil	Beyaz	Yeşil / Siyah	Sarı / Siyah	Mavi / Siyah	Kırmızı / Siyah	Gri	Pembe	Mor	Sarı
Brown / Green	Blue	White / Green	White	Green / Black	Yellow / Black	Blue / Black	Red / Black	Gray	Pink	Violet	Yellow

Sensör hattı, güç kaynağı hattı ile içeriden bağlıdır.

The sensor line is connected internally with the power supply.

DİKKAT : Servis gerektiren durumlarda OEM hafıza alanı parametreleri ayarlanmış olmalıdır.

CAUTION: The parameters in the OEM memory area must be adjusted if service becomes necessary.

8.3.2 ERN1387 Encoder

14-pin PCB connector

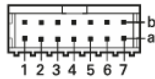

	Voltage supply					Incremental signals					
	1b	7a	5b	3a	/	6b	2a	3b	5a	4b	4a
	U _P	Sensor U _P	0V	Sensor 0V	Internal shield	A+	A-	B+	B-	R+	R-
	Brown/ Green	Blue	White/ Green	White	/	Green/ Black	Yellow/ Black	Blue/Black	Red/Black	Red	Black

	Other signals					
	7b	1a	2b	6a	/	/
	C+	C-	D+	D-	T ¹⁾	T ⁻¹⁾
	Gray	Pink	Yellow	Violet	Green	Brown

Cable shield connected to housing;

U_P = Power supply; T = Temperature

Sensor: The sensor line is connected internally with the corresponding power line.

Vacant pins or wires must not be used.

¹⁾ Only for cables inside the motor housing

akarasansor.com



AKAR ASANSÖR MOTOR MAKİNA SAN.LTD.ŞTİ

Selimpaşa Mah. 5006 Sokak
No: 18 34590 Silivri / İSTANBUL / TÜRKİYE

t: +90 212 723 86 78 f: +90 212 723 86 80