

CONTENTS

1. General Information.....	3
1.1. DAK Series Machines/Motors	3
1.2. Framework of Installation and Maintenance Manual	3
1.3. User	3
1.4. Copyright	3
2. Safety Instructions.....	4
2.1. General	4
2.2. Technical Personnel Responsibilities	4
2.3. Symbols and Signs used in Operating Manual	4
2.4. Safety Instructions	5
3. Product Information	6
3.1. Machine / Motor Weights and Oil Capacities.....	6
3.2. Operating Area.....	7
3.3. Transportation and Packaging.....	7
3.4. Storage Conditions.....	8
4. Mechanical Installation	9
4.1. Mechanical Safety Warnings	9
4.3. Rope Safeguard Arm Adjustment.....	10
5. Electric Connections	10
5.1. Electric Safety Warnings	10
5.2. Motor Terminal Connections	10
5.3. Encoder Connection.....	13
5.4. Electromagnetic Brake Connection	13
5.5. Electromagnetic Brake Types and Specifications.....	14
6. Operating.....	15
6.1. Operating Conditions	15
6.2. Control Chart - Check List.....	15
6.3. EN 81-1:1998+A3:2009 Brake Tests.....	16
6.4. Operating in Emergency Situations	16
7. Failure and Recommendations.....	18
8. Service and Maintenance	20
8.1. General Information about Maintenance	20

8.2. Periodical Maintenances	20
8.3. Encoder Connection Instructions	20
8.4. Encoder Mounting	21
8.4.1. DAK125 and DAK135 Encoder Mounting (FORMER TYPE-1).....	21
8.4.2. DAK125 and DAK135 Encoder Mounting (FORMER TYPE -2).....	22
8.4.3. DAK125 and DAK135 Encoder Mounting (NEW TYPE).....	23
8.4.4. DAK170 and DAK190 Encoder Mounting (FORMER TYPE)	24
8.4.5. DAK170 and DAK190 Encoder Mounting (NEW TYPE).....	25
9. Product and Part Lists	26
9.1. DAK80 Machine / Motor	26
9.2. DAK125 Machine/Motor	28
9.3. DAK135 Machine/Motor	29
9.4. DAK170 Machine/Motor	32
9.5. DAK190 Machine/Motor	35
10. Label Information	38
10.1. Machine Label	38
10.1. Motor Label	38
11. Chassis Types Recommended for Machine / Motor	39
11.1. Sample of Chassis Placed on Concrete basement.....	39
11.2. Steel Construction Used Chassis Sample	39
12. Support Bearing Installation	40

1. General Information

1.1. DAK Series Machines/Motors

DAK series machines / motors have been designed for elevators using rope and traction sheave system. **Other drive implementations are not permitted without approval of AKAR.**

DAK series motors are convenient for machine room systems. As they are convenient to open/closed cycle with elevator operator, double-speed models of them can also be used with direct line voltage.

1.2. Framework of Installation and Maintenance Manual

This manual has been designed as a part of machine / motor to be taken as reference if it is necessary. The personnel responsible with installation, operation, maintenance or repair are obliged to read and understand this manual completely and to follow the instructions in this manual.

AKAR is not responsible with the damages and breakdowns arising because of ignoring this manual.

AKAR reserves its right to make changes in this manual in accordance with technical developments if it is deemed necessary.

1.3. User

This manual has been prepared for the personnel who will take place in installation, maintenance, operating and repair.

1.4. Copyright

All kinds of copyrights of this manual belong to Akar Asansör Mot. Mak. San. Ltd. Şti. (İstanbul) (AKAR Elevator Motor Machinery Industry Ltd. Co.). Information given in this manual can be changed without a prior notification. Without written consent of AKAR, no part of this manual can be copied or distributed electronically or mechanically whatever the reason it is.

2. Safety Instructions

2.1. General

DAK series machines / motors are not a ready to use product for end users. Before taking into operation; Safety equipment for installation (which may vary according to implementation) should be completed. Reliability and performance of the system depend on making installation of each of the parts right and safely.

2.2. Technical Personnel Responsibilities

Installation, electric connections, operation, maintenance and repair services should be made by authorized and qualified technical personnel with respect to relevant standards and regulations.

2.3. Symbols and Signs used in Operating Manual

Symbols and signs below have been used with the purpose to remark the hazardous area, useful information and recommendations for the user.

	DANGER! Severe injury may occur! Hazardous area! In case of not taking precautions death or severe injury may occur.
	ATTENTION! Material damages may occur! In case of not taking precautions material damages may occur.
	DANGER! Electric shock risk! Dangerous electric voltage area. In case of not taking precautions death or severe injury may occur.
	INFORMATION! Additional information for users.
	RECOMMENDATION! Tips and recommendations for users.

2.4. Safety Instructions

Motor as it was informed during order procedure, can only be used either specific purposes or elevator systems.

Motor should only be operated with the parameters indicated in label values.



There is a handling ring on the motor. Ring has been designed **only** to carry motor, brakes and traction sheave. Do not load externally (for example: ropes, sockets etc.)



In case of current is not pass from motor, it will not generate tork. In this case, if the brakes are open, cabin will move uncontrolled. **Therefore, it is strongly recommended that motor windings should be short-circuited.**

Then, speed will depend on brake tork similar to traction sheave friction in machine-motor systems. **Short-circuit should be made at the contactor tips of the main contacts. Motor windings can only be short circuited when current is not passing from windings.**



Safety equipments controlling brake vibrations should not be removed and neither be activated.



While motor shaft is spinning, induced voltage is applied to motor connection tips!



Motor should only be used earthed power cable with groud lead. Please be sure that the groud lead of the motor and groud lead of the building are different.



The tips of U, V, W phases ob the power cable should be connected in line with indicated in auto-tuning process.



DAK series motors are being protected with PTC thermistors connected to phase windings against overheating. Connections should be made via PTC controller and maximum 30V DC should be applied. **Higher voltage values damage PTC and motor goes beyond the warranty scope.**



Brake coils are designed according to voltage value in brake label values. Do not go out of $\pm 5\%$ tolerance for applied DC voltage.



Encoder connection diagrams are given in *8.3 Encoder Connection Diagrams* section for different connection types. Connections should be made according to given information.



In case of unseal the red seal; motor will go beyond the warranty scope. If dismantling procedure is necessary, contact to the producer.



Encoder cable should be insulated from the electromagnetic interaction arise from main power cable. Otherwise, parasitic current, invertor errors and disconcerting of course comfort.

3. Product Information

3.1. Machine / Motor Weights and Oil Capacities

Machine Type	Machine Power						Motor Weight			Machine Weight		Oil Capacity		
	PS			kW			Kg			Kg		Motor	Machine	
												lt	lt	
DAK80	0,75 AC1	1,00 AC1	1,50 AC1	0,55 AC1	0,75 AC1	1,10 AC1	9,0	10,6	13,0	70		---	1,25	
DAK80 T	0,75 AC1	1,00 AC1	1,50 AC1	0,55 AC1	0,75 AC1	1,10 AC1	9,0	10,6	13,0	80		---	1,25	
DAK125	5,50 3VF		7,50 3VF		4,00 3VF		5,50 3VF			260		---	5	
	5,50 AC2		7,50 AC2		4,00 AC2		5,50 AC2			305		---	5	
DAK135	5,50 3VF	7,50 3VF	10,00 3VF	12,50 3VF	4,00 3VF	5,50 3VF	7,50 3VF	9,00 3VF			285 - 295	---	5,25	
	5,50 AC2		6,70 AC2		4,00 AC2		5,00 AC2					320	---	5,25
	7,50 AC2		10,00 AC2		5,50 AC2		7,50 AC2					340	---	5,25
DAK170	10,00 3VF	12,50 3VF	15,00 3VF	18,50 3VF	7,50 3VF	9,00 3VF	11,00 3VF	13,60 3VF			385	---	6	
	10,00 AC2		13,30 AC2		7,50 AC2		10,00 AC2					420	---	6
DAK190	18,50 3VF		23,70 3VF		13,60 3VF		17,70 3VF					700	0,125	12
	16,00 AC2	18,50 AC2	20,70 AC2		12,00 AC2	13,60 AC2	15,00 AC2				700	0,125	12	

AC1	Single-speed
AC2	Double-speed
3VF	Variable Speed – Variable-frequency Driver

<p><i>Recommended Mineral Machine Oils</i></p> <p>Mobil Gear 630</p> <p>Shell Omala 220</p> <p>Petrol Ofisi 220</p> <p>BP Energol GR-XP 220</p> <p>Belgin Recompond 220</p>	<p><i>Recommended Synthetic Machine Oils</i></p> <p>Mobil SHC630</p> <p>Shell Tivela VB</p> <p><i>Oil types for Motor</i></p> <p>Shell Tellus Oil 46</p> <p>BP Energol HLP 46</p>
---	---

Note: In case of oil usage except the recommended oils machine / motor group will go beyond the warranty scope.

3.2. Operating Area

DAK series machines / motors are convenient for the systems with machine room. They are compatible to work with Double-Speed and Various Speed – Various Frequency Drivers (3VF). For 3VF systems, closed cycle with encoder operating is recommended.

The working area where the motor installed should provide the conditions below;

- ✓ Environment temperature should be between 0 °C + 40 °C values.
- ✓ Up to 1000 m over sea level.
- ✓ Humidity rate should be less than 95%.
- ✓ Driver should be mounted interior side.
- ✓ Protection level written on the label should be considered.
- ✓ Protective measures against building wastes and external effects (water, damp, dust, etc.) should be taken.



If the operating conditions are different from the specified environment, please contact to producer.

3.3. Transportation and Packaging

Transportation of DAK series machines / motors is being carried out as determined with transportation company.

There is a handling ring on the motor. Ring has been designed **only** to carry motor, brakes and traction sheave.

- ✓ Transport the motor in its original package using its handling ring.
- ✓ Use suitable lifting equipment considering its weight.
- ✓ It is given in the table in *Motor Weights* section
- ✓ Take your measurements to prevent the strikes and vibrations during transportation.



Do not load externally (for example: ropes, sockets etc.)



Pay regard to the center of gravity during transportation.



Check the package for possible damages and losses, where necessary, contact to transportation company. Damages and losses happen in transportation are out of warranty.

3.4. Storage Conditions

In cases when storage is necessary,

- ✓ Keep motors in their original package in a dry area.
- ✓ Take measures for extremely variable climate conditions.
(Recommended storage conditions are; between -20 °C and 60 °C)
- ✓ Take protective measures for external factors (water, damp, dust, etc.) and building wastes.
- ✓ Avoid for long term stocking.
(Recommended maximum stocking period: 1 year)



Before motor mounting; Try by disengaging the brake and rotating the wheel. If there is an extraordinary voice, contact to the producer.

4. Mechanical Installation

4.1. Mechanical Safety Warnings

Mechanical installation should only be performed by authorized and trained staff.

During installation, conformity to standards is under the responsibility of contracted company.

If you encounter a problem, please contact to the producer company. (Contact information take place back cover of this manual).

- ✓ Before installation, check the motor for damages and losses may occur during transportation.



There is a handling ring on the motor. Ring has been designed **only** to carry motor, brakes and traction sheave. Do not load externally (for example: ropes, sockets etc.).

- ✓ **Do not apply any force to motor, brake or traction sheave.**
- ✓ Motor and particularly brakes should be protected against dump, water, dust and building residuals.
- ✓ Air flow around the motor should not be prevented in any way. Otherwise, it causes overheating of the motor.



To be able to access encoder, leave at least 150 mm (horizontally) distance between shaft wall and brakes.



Brake mountings on DAK series motors are ex-factory. Brake adjustments are made by Akar. **Please do not make any adjustment!** Otherwise, motor and brakes will be out of warranty.

Brake replacement should be within the knowledge of Akar. If brake replacement is necessary contact to our company.



In case of any intervention to motor, brakes and accessories; motor will be out of warranty.

4.3. Rope Safeguard Arm Adjustment

There are 2 each of rope safeguard arms on the machine.

- ✓ Both rope safeguard arms should be fixed to the kernels on the body of the machine.
- ✓ Make the connections of rope safeguard arms, paying attention to the coiling angle of the ropes.
- ✓ The distance of rope safeguard arms to ropes should be maximum 3mm.

5. Electric Connections

5.1. Electric Safety Warnings

Electric connections should only be performed by authorized and trained staff.

Conformity to standards of the installation is under the responsibility of contracted company.

In any problem, please ask support from AKAR. (Contact information take place back cover of this manual).

Before the installation of motor, be sure that cables did not damage during transportation.

5.2. Motor Terminal Connections

- ✓ Make motor terminal connections in accordance with the enclosed circuit diagram (*Figure-2/3*).
- ✓ **Check the earthing lead and be sure its accuracy.**
- ✓ Motor should only be used with shielded power cable having earthing lead. Please ensure that the earthing lead of the power cable is different from building earthing.

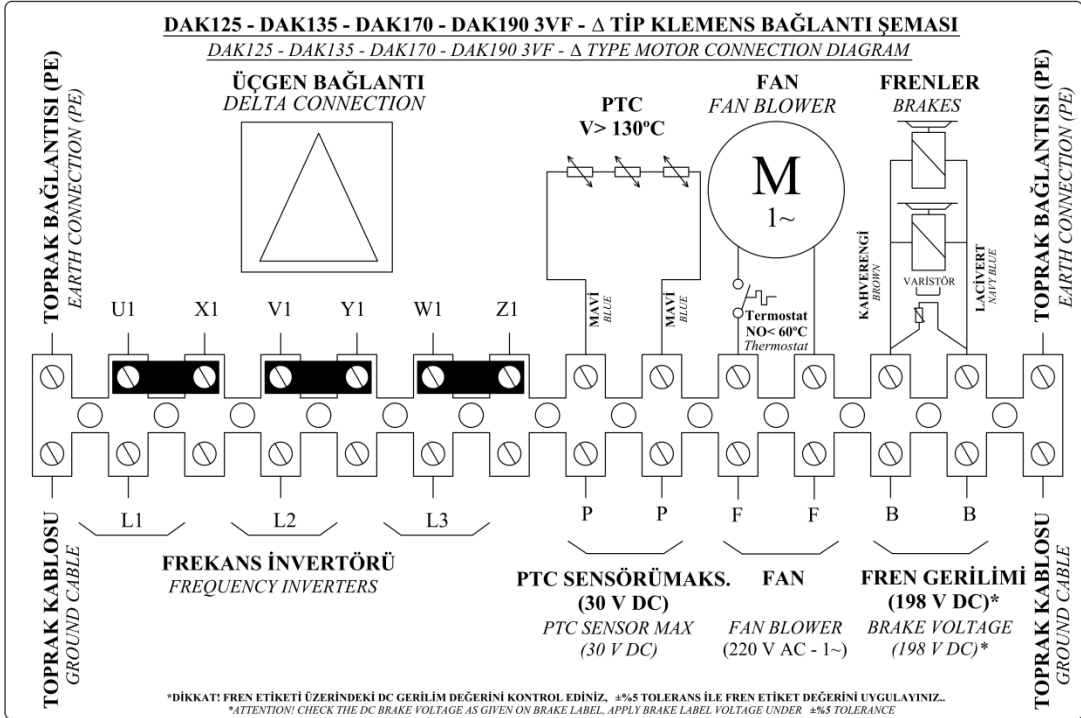
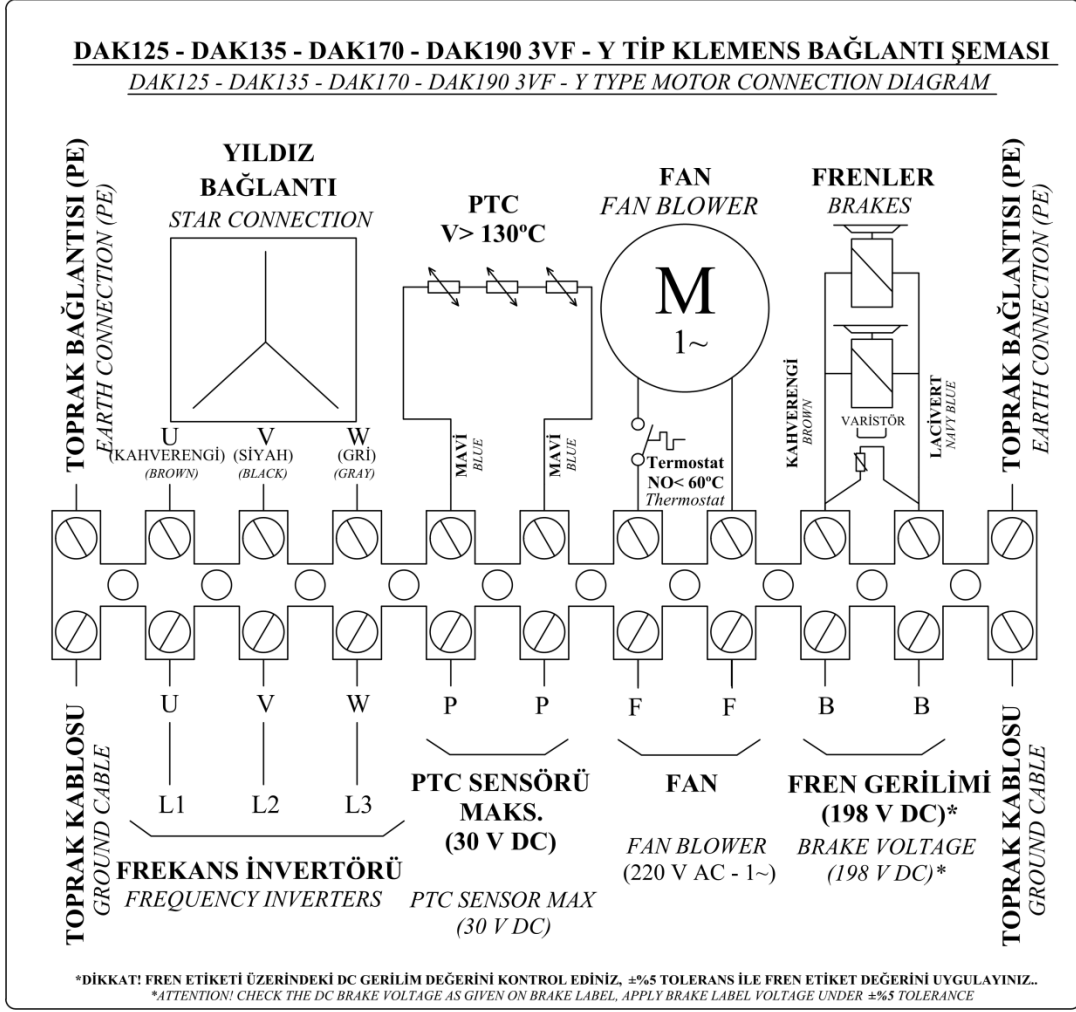

Figure 1- DAK125 – 135 – 170 – 190 3VF Type Y and Δ Terminal Connection Diagram

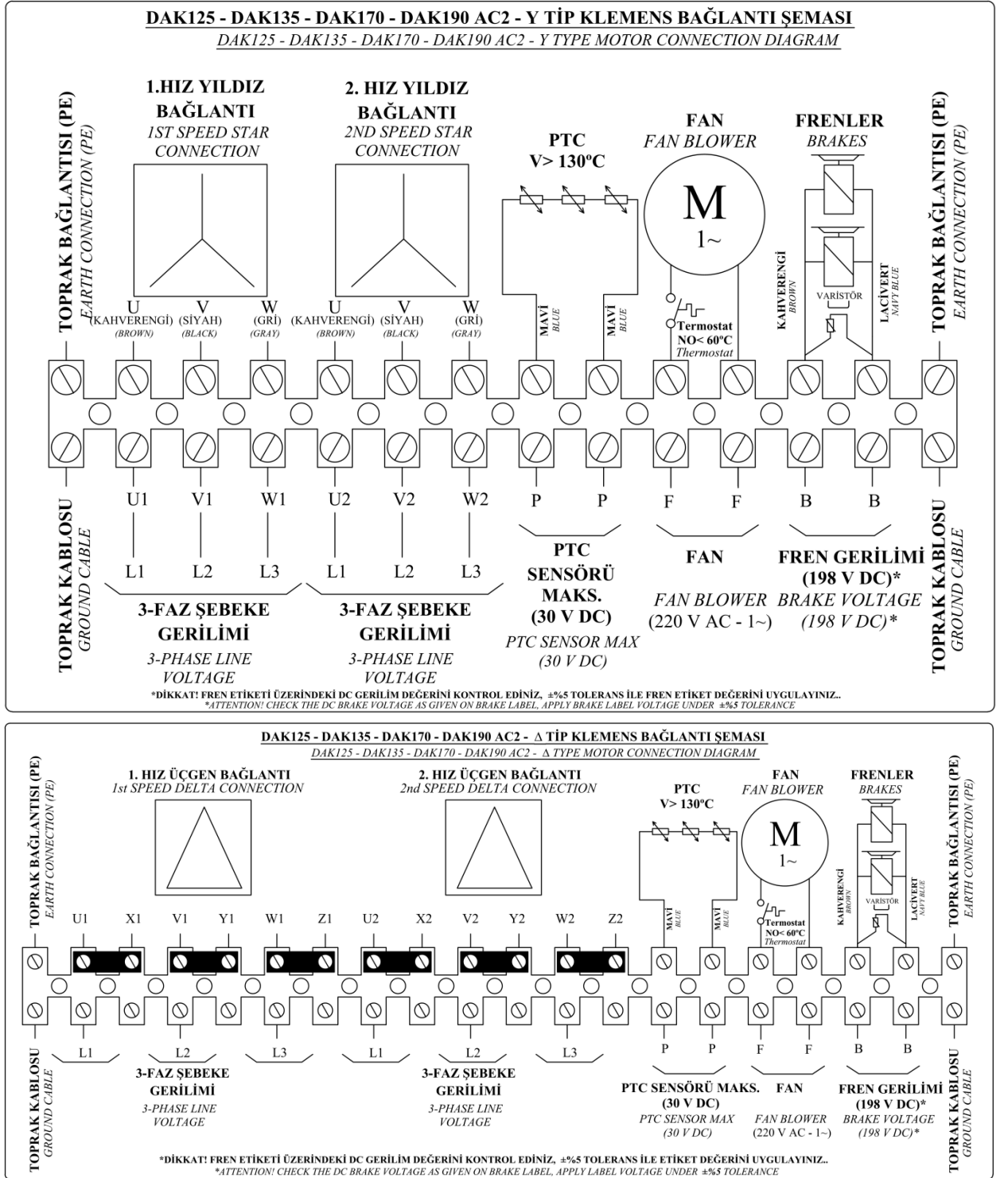

Figure 2- DAK125 – 135 – 170 – 190 AC2 Type Y and Δ Terminal Connection Diagram



DAK series motors are being protected with PTC thermistors connected to phase windings against overheating. Connections should be made via PTC controller and maximum 30V DC should be applied. **Higher voltage values damage PTC and motor goes beyond the warranty scope.**

5.3. Encoder Connection

On the DAK series machines / motors, encoder is mounted to motor shaft by producer or externally given in the box in package.

- ✓ Unless indicated otherwise, encoder is supplied with 7 meters shielded cable.
- ✓ **Encoder should be compatible with the software of inverter.**
- ✓ Encoder color codes have been given at *8.3 Encoder Connection Diagrams* section.
- ✓ Make encoder connections in accordance with *8.3 Encoder Connection Diagrams*.



Replacement of encoder should only be performed by authorized and trained staff. In case of replacement, encoder should be introduced to inverter again.



Protect encoder against mechanical impacts for not to cause measurement failures.

Do not directly touch encoder and encoder cable. Encoder is precise for electrostatic discharges and it may break down as a result of discharge.

5.4. Electromagnetic Brake Connection

On DAK series motors, electromagnetic brakes are mounted by producer. Brake adjustments made by AKAR.

- ✓ Connections of electromagnetic brakes should be made as shown on brake label and brake connection diagram. Brake connection diagram has been shown in Figure-10.
- ✓ Electromagnetic brakes are designed for static brake applications. In static brake (stop) applications, abrasion of brake linings is at the minimum level. Therefore brakes do not require maintenance in general.
- ✓ Dynamic brake applications are limited by test braking only made by producer and emergency braking.

5.5. Electromagnetic Brake Types and Specifications

Motor Type	Brake Tension (V)	Brake Power (W)	Brake Current (A)	Fuse	Suitable Cable Section
DAK80	24 V DC	38,66 W	1,61 A	4,00 A	0.50 mm
	48 V DC	38,72 W	0,81 A		
	60 V DC	34,12 W	0,57 A		
	198 V DC	39,60 W	0,20 A		
DAK125 DAK135 DAK170	48 V DC	109,71 W	2,29 A	4,00 A	0.75 mm
	60 V DC	120,00 W	2,00 A		
	110 V DC	156,13 W	1,42 A		
	198 V DC	237,60 W	1,20 A		
DAK190	48 V DC	102,40 W	2,13 A	4,00 A	0.75 mm
	60 V DC	111,80 W	1,86 A		
	198 V DC	216,60 W	1,09 A		

(Standard brake voltage is for DAK80 group 48V DC and for all other groups 198V DC)



To the tips of brake coil;

Applying voltage less than working voltage will cause not to perform its duty completely. In this case, there may be brake friction voice, motor may draw excess current, motor may overheat or driver may start to give error.

Applying voltage more than working voltage on the other hand will cause rapid heating of brake.

6. Operating

6.1. Operating Conditions

Operating area where machine and motor installed should provide the below conditions;

- ✓ Environmental temperature should be between the values of 0 °C + 40 °C.
- ✓ Altitude should be up to 1000 m over sea level.
- ✓ Humidity rate should be less than 95%.
- ✓ Driver should be mounted interior side.
- ✓ Check the protection class written on the label.
- ✓ Take protective measures against building residuals and external effects (water, damp, dust, etc.).



Motors should not be operated in the environments containing explosive gas.



If the operating conditions are different from the specified environment, please contact to producer.

6.2. Control Chart - Check List

Before operating the motor, ensure that the below conditions are met:

- ✓ Insulation and operating conditions should be similar to label values and this manual.
- ✓ Motor operating conditions should be similar to label values.
- ✓ Brake tension voltage supply should be similar to label values.
- ✓ Mechanical and electric connections should be adjusted in accordance with this manual.
- ✓ Ensure that motor has been fixed to the horizontal platform in balance dues.
- ✓ Control the accuracy of rotation direction of the motor.
- ✓ Control the electrical insulation resistance is sufficient.
- ✓ Ensure that the air flow around motor is not prevented.
- ✓ Ensure that safety equipment connected in the correct way.
- ✓ Control that earthing has been made correctly.
- ✓ Check that PTC controller supplied with max. 30 V DC
- ✓ Ensure that necessary precautions have been taken for all the parts moving under electric voltage.
- ✓ Ensure that the load distributed evenly between the ropes.
- ✓ Observe that motor is operating silent and without vibrating.
- ✓ Ensure that placement bolts mounted correctly.
- ✓ Ensure that all cable entries closed.



Please beware that the above list does not comprise all possible cases. Additional tests and controls may become necessary. Therefore; **starting and commissioning processes should be carried out by authorized and experienced staff that has got knowledge and experience on this matter.**



All tests defined for EN81-1 enclosure D2 h should be made before the elevator taken into service.

6.3. EN 81-1:1998+A3:2009 Brake Tests



It is recommended that the tests are made when elevator cage is at the halfway of elevator pit.

a) Overload Test

Overload test; should be performed when it is loaded 125% of label value on the motor and moving down with nominal speed. Power of motor and brake should be de-energised.

b) Single Brake Trouble Test (only for Double Brake Systems)

If motor has got double brake system, test should be performed with a single brake at nominal speed and load written on the label values. Power of motor and brake should be de-energised.

WARNING 1: During the performance of test; one of the brakes should be released, other brake operated separately and tested.

WARNING 2: During the performance of test; elevator system should be observed carefully. **If there is no decrease in speed, other brake should be activated promptly.**

6.4. Operating in Emergency Situations

Operating in emergency situations should be made only by authorized and trained staff.

a) Electric operating in Emergency Situations

Operating in emergency situation should be compatible with the requirements of electric operating in emergency situations (above) and in this situation it is necessary to work on the relevant machine areas:

- Engine room,
- Machine cabinet or
- Emergency situation and test panels.

At the same time, it should meet the determined requirements of 14.2.1.4:

- a) Electric manual control switch should allow controlling the cage movement by continuously pressing the buttons protected against by mistake. Movement directions should be marked clearly;
- b) After activating the electric manual control switch, all cage movements except controlled by this switch should be interrupted.

When maintenance control proceeded, electric manual control switch should be shut down;

c) Electric control switch itself or another electric switch compatible to Article 14.1.22 should shut down below electric devices:

- 1) The ones installed to safety mechanism according to Article 9.8.8;
- 2) The ones on the speed regulator according to Article 9.9.11.1 and Article 9.9.11.2;
- 3) The ones installed to safety appliance against excessive accelerating of the cage upward according to Article 9.10.5;
- 4) The ones installed to shock absorbers according to Article 10.4.3.4;
- 5) Limitation safety disconnectors according to Article 10.5

d) Electric manual control switch and its push buttons should be placed in a way to see the drive machine directly or via display devices (Article 6.6.2 c));

e) Elevator cage speed should not exceed 0.63 m/s.



For emergency situation works, it is recommended to use an uninterrupted power supply (UPS) or a storage battery.

b) Emergency Situation Mechanical Operation (Releasing Brakes)

Emergency situation mechanical operation should be applied only and only there is no other alternative to rescue. (Brake burning etc.)



To prevent uncontrolled acceleration of the cage, **it is strongly recommended that motor windings should be short-circuited.**

Then, speed will depend on brake torque similar to traction sheave friction in machine-motor systems. **Short-circuit should be made at the contactor tips of the main contacts. Motor windings can only be short circuited when current is not passing from windings.**

Emergency situation mechanical operation should be applied by authorized and trained staff by following the safety instructions provided below:

- ✓ Emergency situation mechanical operation should be made by using brake release apparatus.
- ✓ Ensure that motor winding tips have been short-circuited. (Short-circuit is important for motor shaft's not to be released. Otherwise, as a result of becoming released of the motor shaft, motor will accelerate uncontrolled in the direction of weighty side of the system).
- ✓ Thus the cage will move with a constant speed depends on brake torque in the direction of weighty side of the system.
- ✓ When you want to stop the system, shut down the brake.



AKAR under no circumstances responsible with inconvenient use of brake release arm.

c) Operating in Power Failure

Operating in power failure status is applied to bring the cage to floor level and to provide disembark when power fail happens and the cage could not reach floor level. This working would be made with uninterrupted power supply (UPS).



Operating in power fail status and emergency situation operation processes are applied separately and could not be used to substitute each other.

7. Failure and Recommendations

	Failure / Possible Breakdown	Possible Reason	Recommendation
1	Leakage of electricity on motor block	Earthing procedure has not been performed	Earthing leas cable should be connected to motor block
2	Motor is not rotating	Brake is not releasing	See Failure 5 “ <i>Brake is not releasing</i> ” section in Table
		Phase tips connected incorrect.	Check U, V, W tips connected to motor electric terminal
3	Motor draws excess current	Brake is not pulling completely	See Failure 5 “ <i>Brake is not releasing</i> ” section in Table
		Phase tips connected incorrect.	Check U, V, W tips connected to motor electric terminal
		Counter-balance is unbalanced	Cage is loaded with a half load, directed to the sub ground floor and to the top floor, the currents during down and up are monitored via driver screen. During down and up, the currents drawn should be close to each other passing through the middle point of elevator pit.
4	Motor operating noisy	Brake is not releasing completely	See Failure 5 “ <i>Brake is not releasing</i> ” section in Table
		VVVF driver settings are incorrect	VVVF driver settings should be controlled
5	Brake is not releasing	Brake supply voltage is low	Supply voltage should be brought to the voltage level indicated on brake label
		Brake coil is burned	Contact to our company
		Working gap between brake disc and brake block is out of permitted range (max.0,6mm)	Contact to our company
6	Braking is not happen	When brakes are closing, voltage is applied	Power supply should be checked
7	Unstable braking	Brake supply voltage is low	Supply voltage should be brought to the voltage level indicated on brake label
8	Noisy braking	VVVF driver settings are incorrect	VVVF driver settings (parameters relevant to stopping moment) should be controlled
		During normal operating work, switching in DC part	<i>Control 5.4 Electromagnetic Brake Connection section of the manual and make AC switching</i>
		Brake air space is more than what it should be (max. 0.6)	Contact to our company
9	Distorted rotating of the brake coupling.	Taking knock onto brake coupling during transportation or carriage	Read the transportation section and contact to service department

	Failure / Possible Breakdown	Possible Reason	Recommendation
10	Improper working of abutment bearing or slope bearing	Tightened mounting of abutment to chassis	Abutment and machine should be connected at the same elevation. Abutment should be revised.
11	Noise coming from thrust ball bearing	Screw receiving knock from traction sheave side	Replace the bearing from bearing replacement page suitable to machine group.
		Breakdown in bearing or balanced working of screw group	Apply to our service department by taking machine and chassis numbers.
12	Oil leakage from any one or both of the machine front bearing and/or thrust ball bearing	Dismounting and mounting again the machine	Machine front bearing and thrust ball bearing stopper seals will be replaced. Front bearing front shall be cleaned. Apply to our service department by taking machine and chassis numbers.
13	Oil leakage from primary shaft caps	Excess filling with operating oil	Control the oil level. Empty excess oil.
		Cutting the o-rings during dismounting and mounting again the machine	It is necessary to replace the o-rings. Contact to our service department.
14	Abrasion of traction sheave	Uneven rope strains	Traction sheave will be replaced and rope strains will be adjusted.
		Incorrect rope type selection	Rope will be replaced and traction sheave will be renewed.
15	Gear abrasion	Using inconvenient oil	By taking machine and chassis numbers, apply to our service department for replacement of gear.
16	Noisy working of machine/motor	Tightened mounting the machine onto chassis.	Review all the reasons. If failure continues, contact to our service department.
		Improper type of chassis where the machine mounted.	
		Distorted rotating of the traction sheave	
		Incorrect mounting of abutment	
		Breakdown of thrust ball bearing	

8. Service and Maintenance

**For part replacement and adjustments in machines
(Bearing, Motor, Worm Gear Group, Brake, Mount, Encoder, Traction Sheave)
please contact to producer company.**

8.1. General Information about Maintenance

Service and maintenance implementations should be performed only authorized and trained staff.

- ✓ Follow-up the extraordinary noises during operation or braking.
- ✓ Always comply with the instructions.
- ✓ During emergency situation works, consider that UPS is broken down. Therefore, service staff should keep UPS around.
- ✓ **Electromagnetic brake adjustment is not permitted.** If the distance between brake body and disc exceeds the maximum permitted value, please contact to manufacturer company.

8.2. Periodical Maintenances

Maintenance Name	During commissioning	Inspection intervals
Distance between rope and rope safeguard	Yes	Every 4 months
Functionality test of Power Supply (UPS)	Yes	Monthly
Mounting of block bolts	Yes	Monthly
Traction sheave control	Yes	Monthly
Brake functionality test	Yes	Monthly
Traction sheave safeguard	-	Monthly
Distance between brake body and disc	-	Monthly

8.3. Encoder Connection Instructions

Encoder Type FNC50H-1063V1024-R5

Connection Type

VDC	GND	A	A'	B	B'	Z	Z'
Brown	White	Green	Red	Yellow	Pink	Grey	Blue
Brown	White	Green	Red	Yellow	Pink	Grey	Blue

Encoder Type C50-H1024ZCU410L10

Connection Type

VDC	GND	A	A'	B	B'	Z	Z'
Red	Black	Yellow	Blue	Green	Orange	White	Grey
Red	Black	Yellow	Blue	Green	Orange	White	Grey

8.4. Encoder Mounting

8.4.1. DAK125 and DAK135 Encoder Mounting (FORMER TYPE-1)

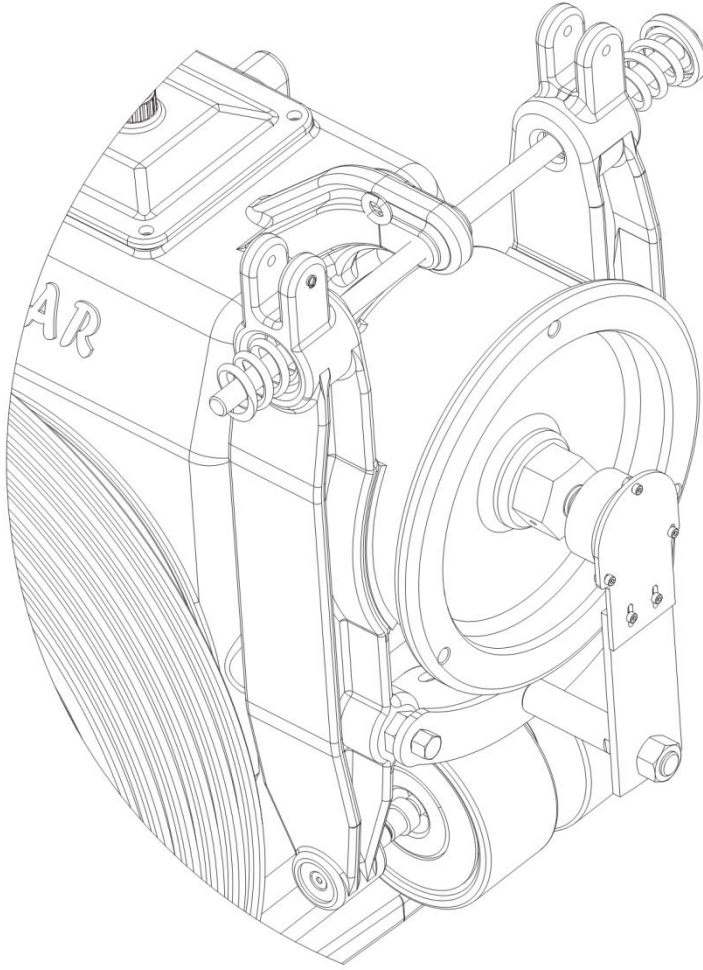

Şekil-1

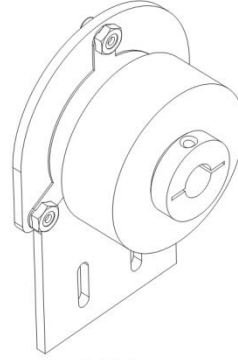

Şekil-3

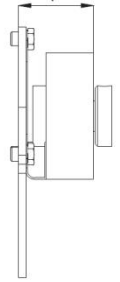

Şekil-4

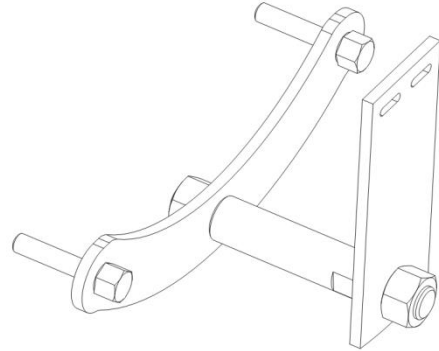

Şekil-2

- Loosen the stay bolt of encoder's coupling shown at Figure – 3 which is received in box and mounted, and snap into its slot. **Do not tighten!!!** (coupling will be tightened last)
- Connect the mounted encoder group in Figure-2 to motor block (Figure – 1)
- Mounted its place as it is shown in Figure-1, affix the encoder's bolts into opened slot channels onto sheet metal. Ensure that encoder is at the center by sliding on shaft.
- Stay bolt metal sheets used for mounting encoder are able to move left or right and up and down. Moving the encoder on the shaft, affix it tightening coupling stay bolts without any clamping.

8.4.2. DAK125 and DAK135 Encoder Mounting (FORMER TYPE -2)

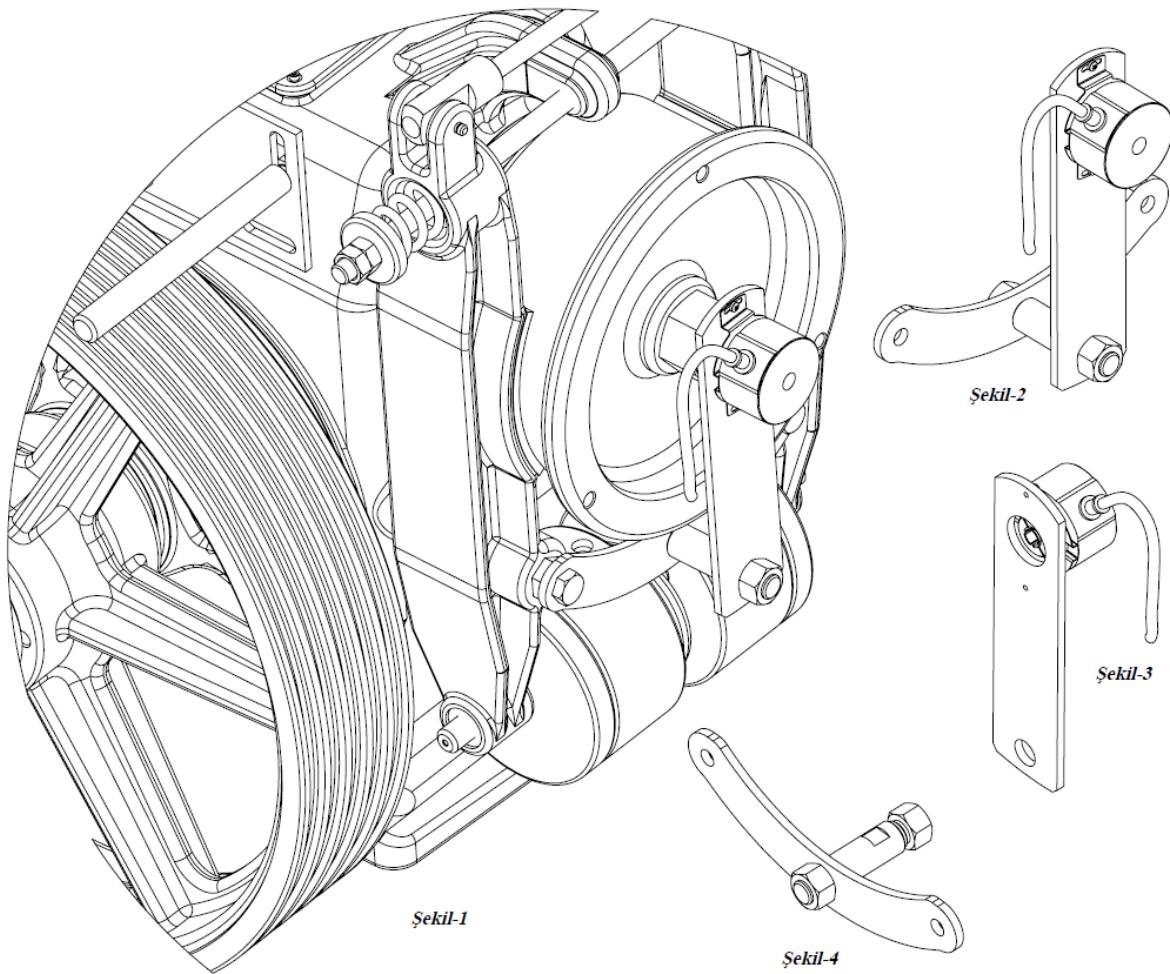

- Encoder goup shown at Figure-4 will come mounted to motor.
- It will come in the box shown at Figure-3 together with motor as mounted to motor.
- Loosen the stay bolt of encoder's coupling shown at Figure – 3 and snap it into its slot. **Do not tighten!!!** (coupling will be tightened last)
- The view at Figure-2 is the view of after mounting as it should be.
- Stay bolt metal sheets used for mounting encoder are able to move left or right and up and down.
- Stay bolt metal sheets used for mounting encoder are able to move left or right and up and down. Moving the encoder on the shaft, affix it tightening coupling stay bolts without any clamping. (Figure-3)

8.4.3. DAK125 and DAK135 Encoder Mounting (NEW TYPE)

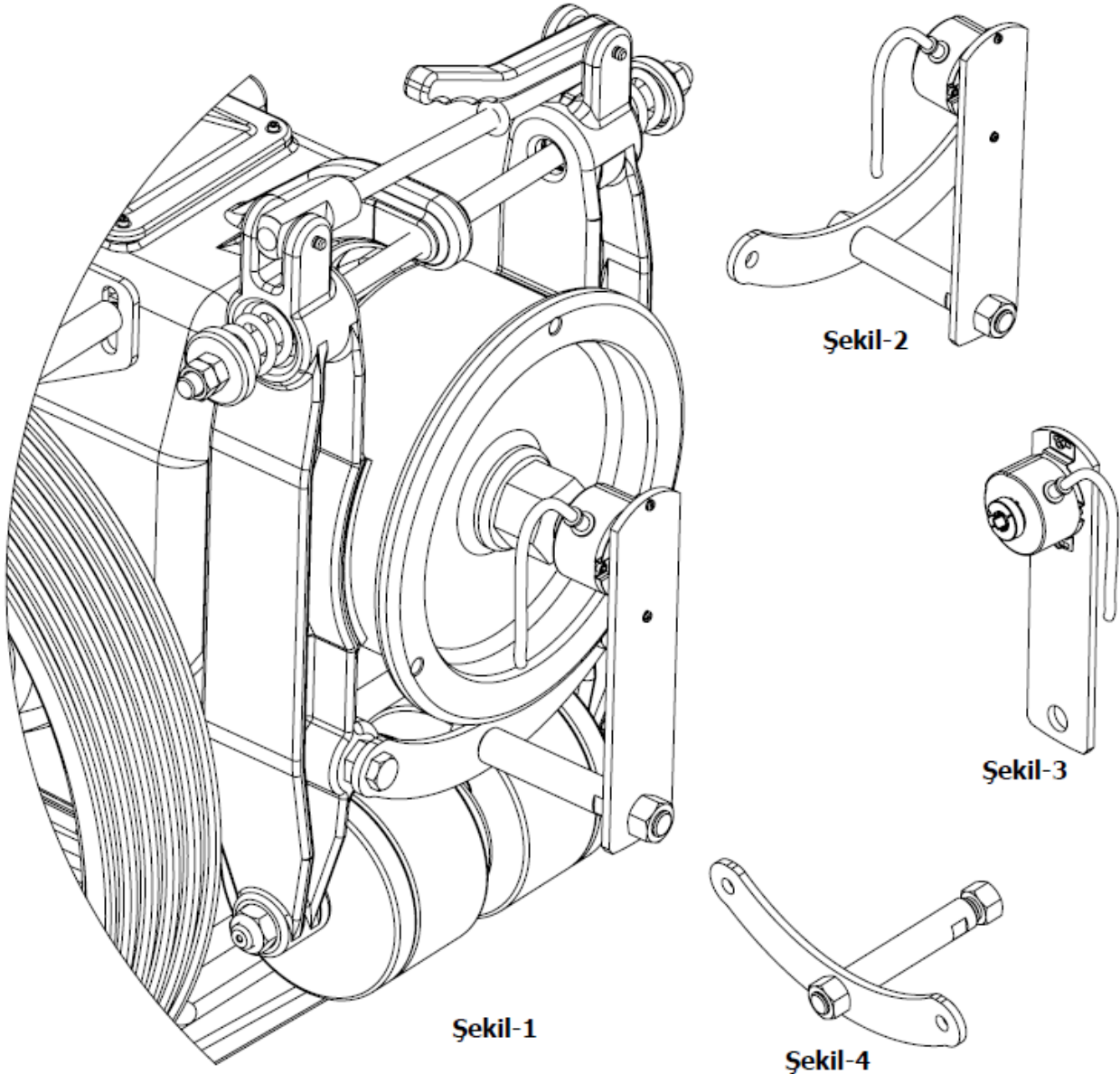

- Encoder goup shown at Figure-4 will come mounted to motor.
- Loosen the stay bolt of encoder's coupling shown at Figure – 3 and snap it into its slot. **Do not tighten!!!** (coupling will be tightened last)
- The view at Figure-2 is the view of after mounting as it should be.
- Stay bolt metal sheets used for mounting encoder are able to move left or right and up and down. Moving the encoder on the shaft, affix it tightening coupling stay bolts without any clamping. (Figure-3)

8.4.4. DAK170 and DAK190 Encoder Mounting (FORMER TYPE)

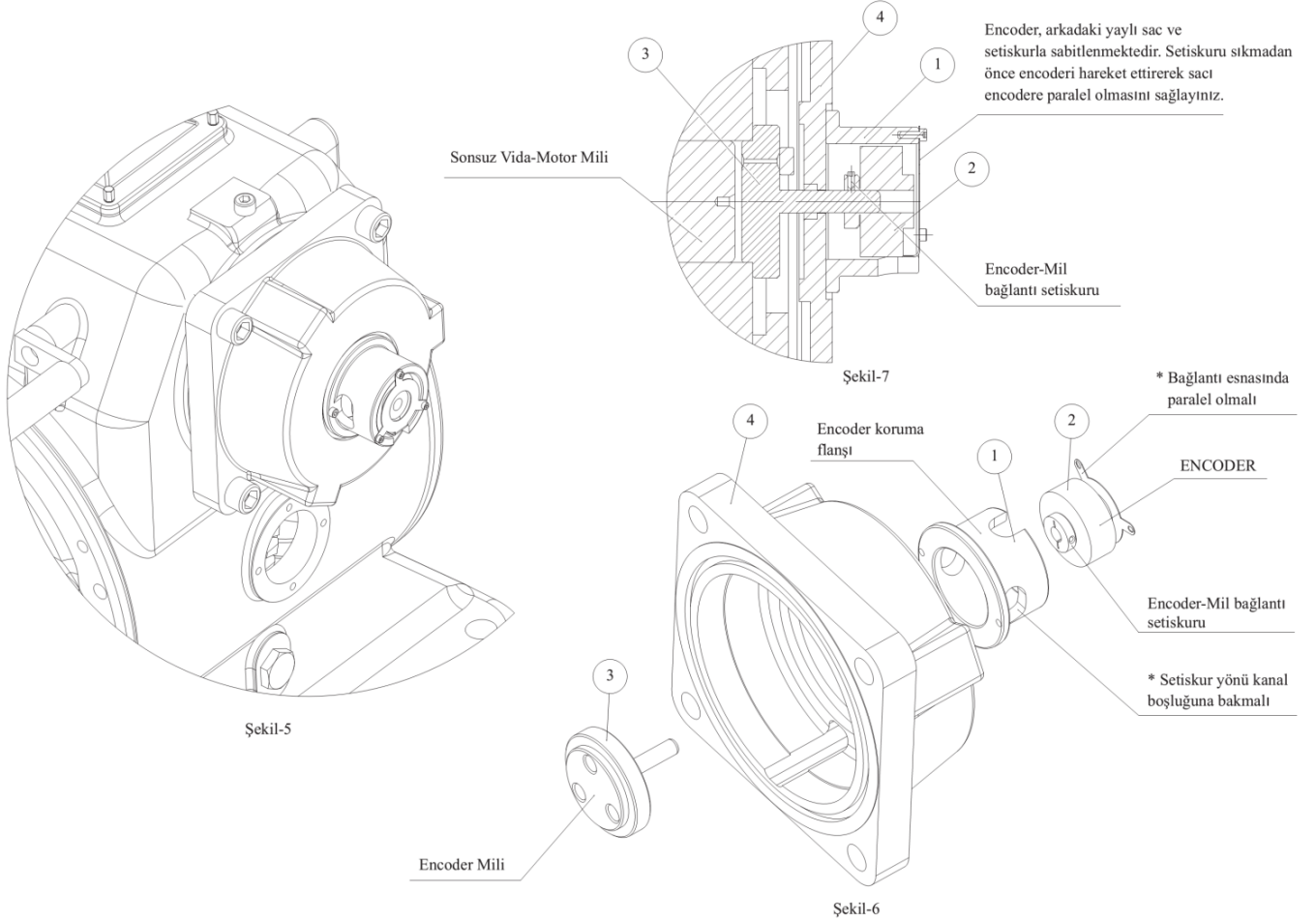

- Taking out the boxed encoder and loosen the coupling stay bolt.
- As it is shown at Figure-7, from the encoder backside sprung metal sheet holes to encoder safeguard metal sheet brackets, affix the encoder onto the (No: 1/3/4) numbered parts mounted on motor.
- From the channels prepared distant for allowing the key to work (No: 1) tighten the stay bolt of coupling without clamping on encoder mounting metal sheet (Figure – 5)
- Encoder coupling stay bolts will be tightened last!!!

8.4.5. DAK170 and DAK190 Encoder Mounting (NEW TYPE)

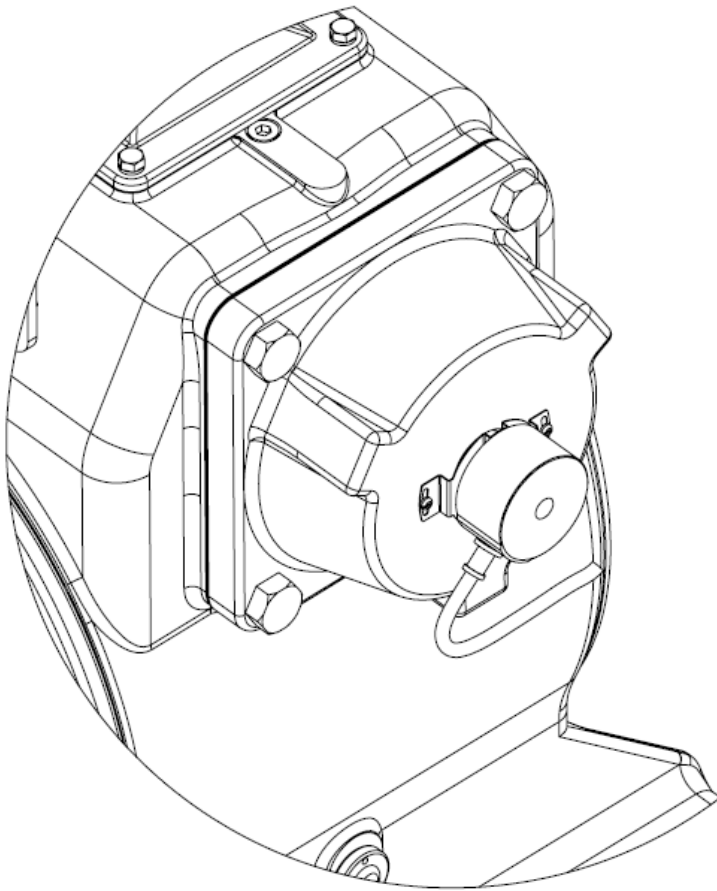

Şekil-1

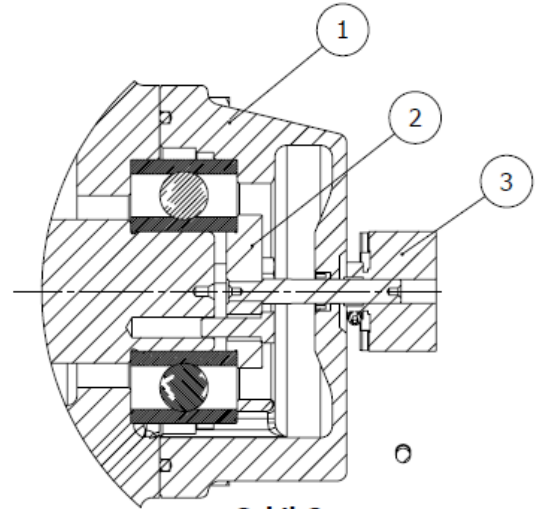

Şekil-2

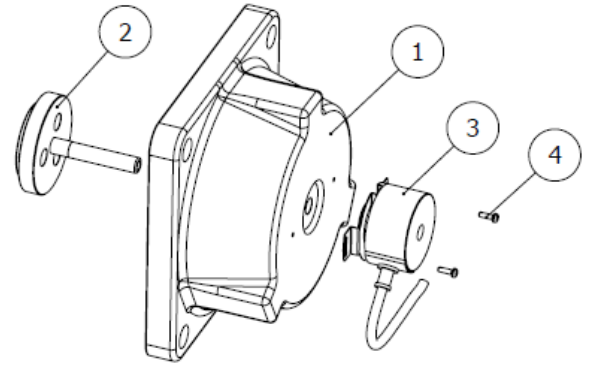

Şekil-3

- Taking out the boxed encoder and loosen the coupling stay bolt. (No:3)
- Cast the encoder upon shaft as at Figure-2 to (No: 3/4) numbered parts mounted on motor, then tighten from encoder metal sheet.
- Tighten encoder coupling stay bolts from the gap between cap and encoder. (Figure – 2)

9. Product and Part Lists

9.1. DAK80 Machine / Motor

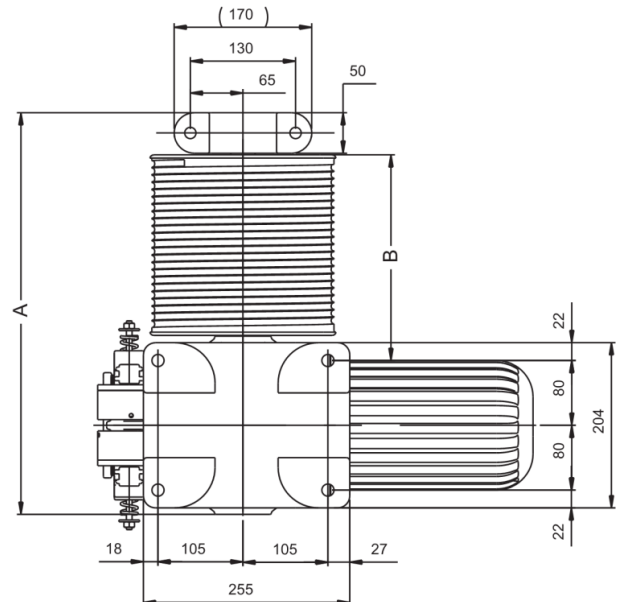
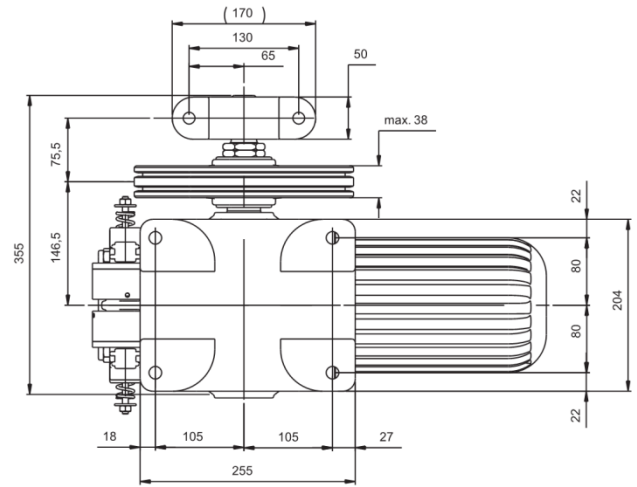
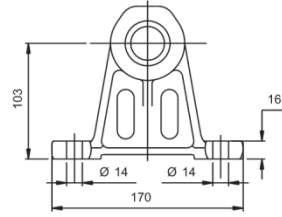
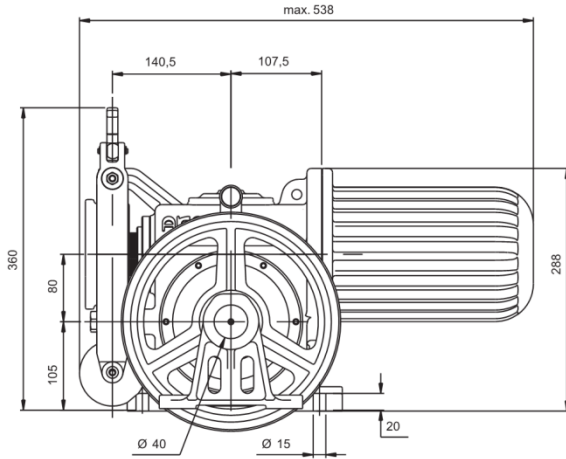

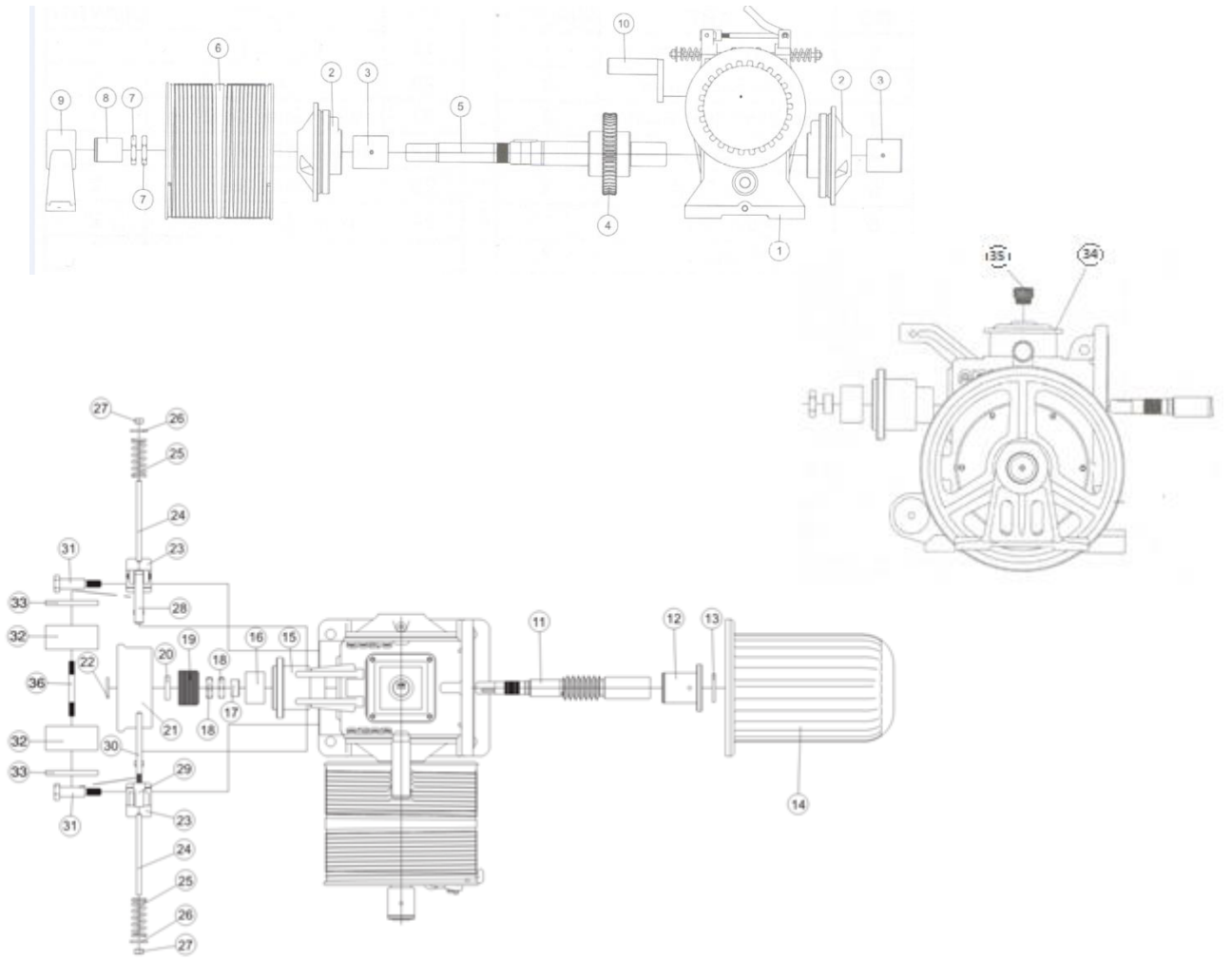

No	PARÇA	Adet
1	Makine gövde	1
2	Ana mil kapağı	2
3	Ana mil burcu	2
4	Sonsuz dişli	1
5	Ana mil	1
6	Tambur/Kasnak	1
7	Kontra somunu	2
8	Yan ayak burcu	1
9	Yan ayak	1
10	Halat muh.	1
11	Sonsuz vida	1
12	Ön yatak	1
13	Keçe $\varnothing 42 \times \varnothing 32 \times 4$	1
14	Motor	1
15	Bute kutusu	1
16	Rulman 52205	1
17	Rulman borusu	1
18	Rulman somunu	2

No	PARÇA	Adet
19	bute tapası	1
20	Keçe $\varnothing 35 \times \varnothing 18 \times 7$	1
21	vida kaplini	1
22	vida kaplini pulu	1
23	fren çenesi	2
24	fren çene saplaması	2
25	fren yayı	2
26	pul	2
27	M8x1,25 somun	2
28	fren kolu	1
29	fren ayar gövdesi	1
30	fren kol saplaması	1
31	fren çene pimi	2
32	fren kutusu bloğu	2
33	fren aynası	2
34	makine üst kapak	1
35	yağ tapası	1
36	fren bobin saplaması	1

9.2. DAK125 Machine/Motor

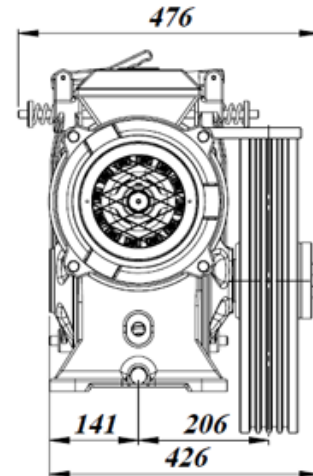
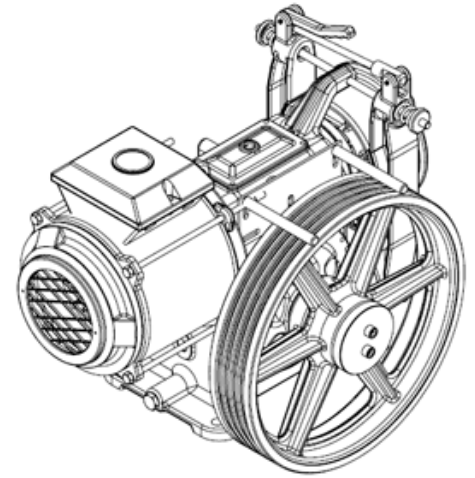
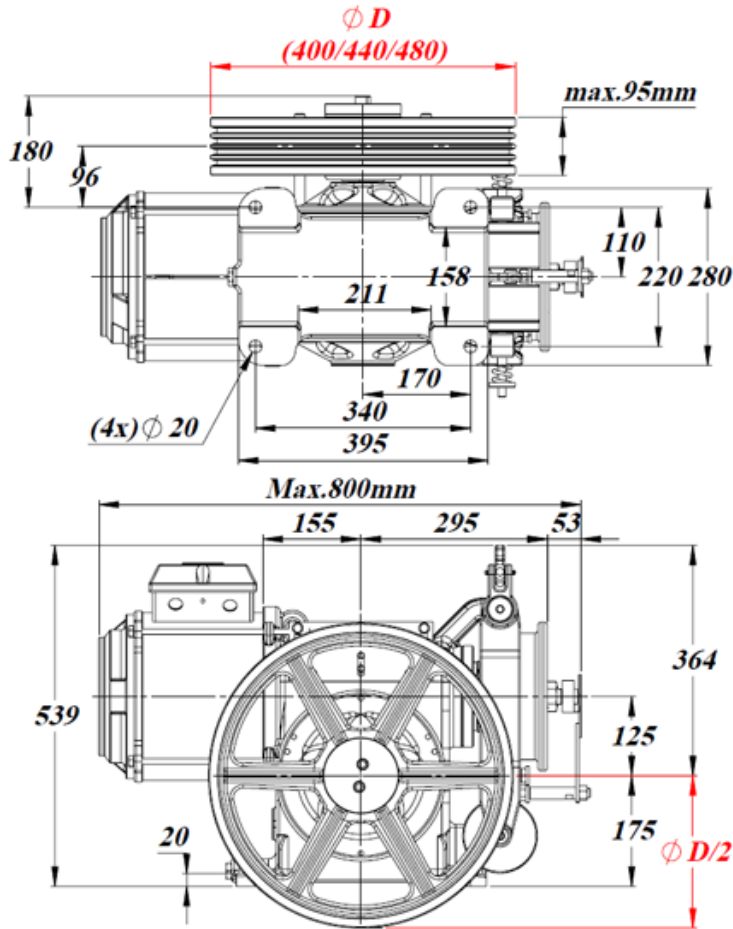

9.3. DAK135 Machine/Motor

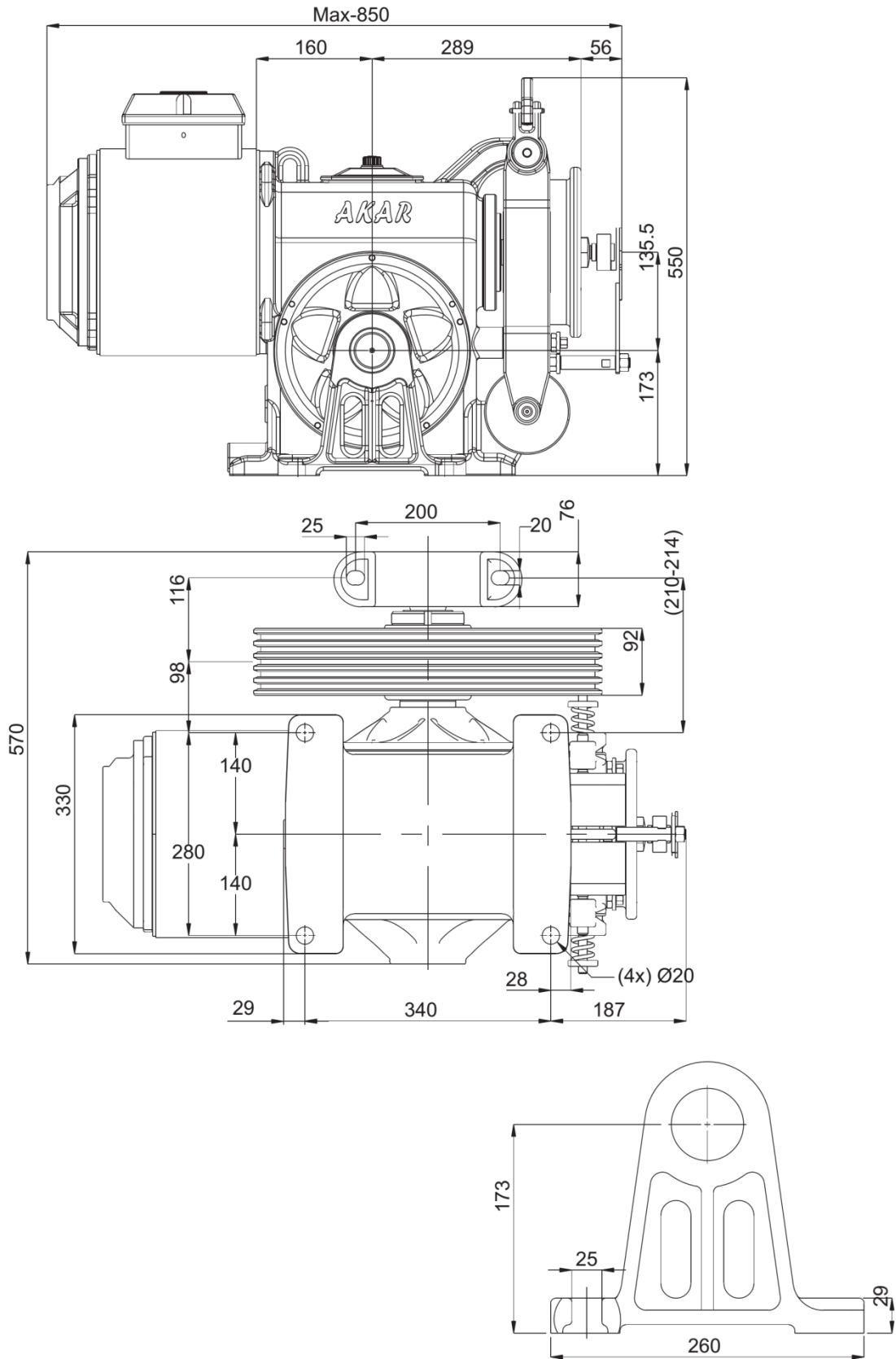

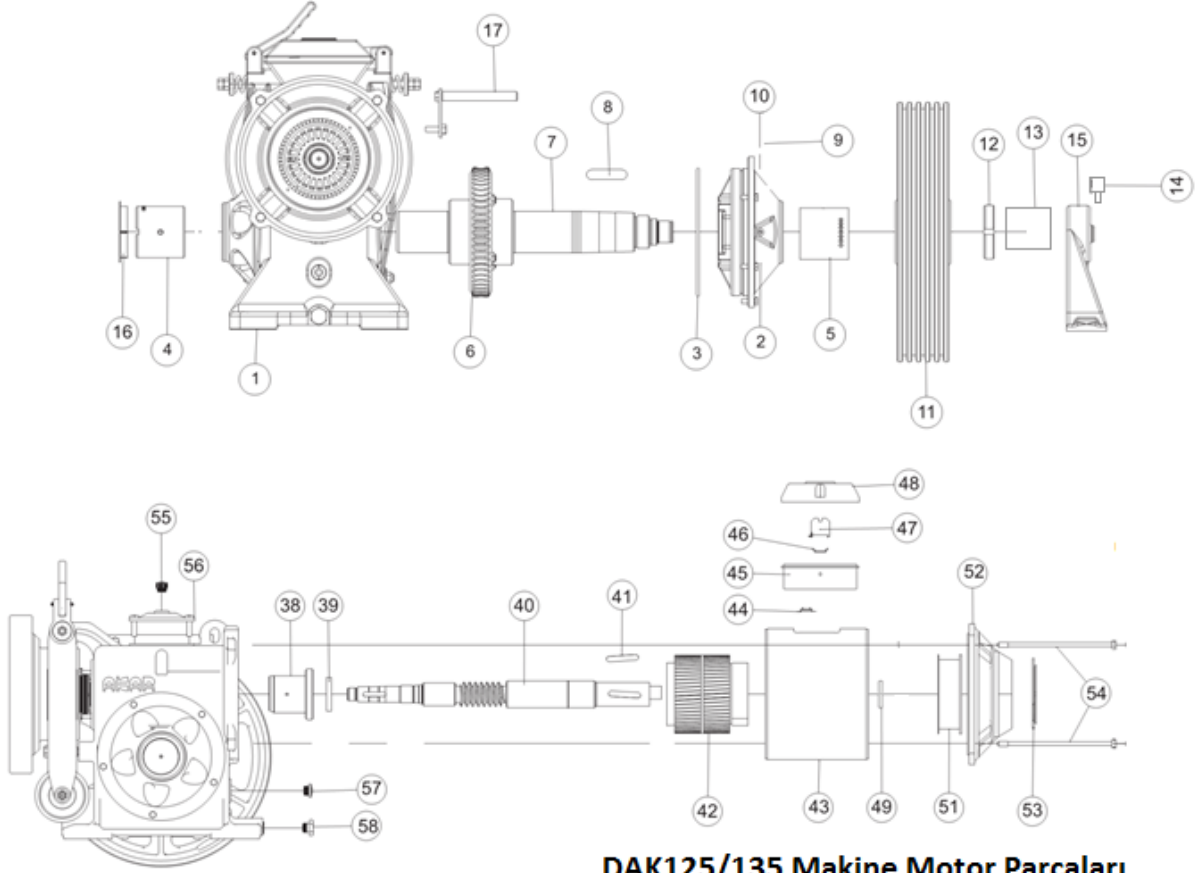

DAK125/135 Makine Motor Parçaları

No	PARÇA	Adet
1	Makine Gövde	1
2	Anamil Kapağı	2
3	O ring Ø200x5	1
4	Anamil Burcu (Sağ)	1
5	Anamil Burcu (Sol)	1
6	Sonsuz Dişli	1
7	Anamil (Burçlu)	1
8	Dak135 Kama 20x12x8 Dak125 Kama 18x11x8	1
9	M8 Pul	1
10	Anamil Bur. Sab.Civt.	1
11	Tahrik kasnağı	1
12	Tah.Kasn.Kont.Som.	1
13	Yan Ayak Burcu	1
14	Glasörlük	1
15	Makine Yan ayak	1

No	PARÇA	Adet
16	Anamil Kapak Tapası	1
17	Halat Muhafaza Kolu	1
18	Bute Kutusu	1
19	Rulman 52210 A	1
20	Rulman Borusu	1
21	Rulman Somunu	2
22	Bute Tapası	1
23	Keçe Ø50xØ35x8	1
24	Bute Kut.Kont.Som.	1
25	Fren Kaplini	1
26	Volan Kilit Som. / Enkoder Bağ. Som.	1
27	Fren Kutusu Bloğu	2
28	Fren Aynası	2
29	Fren Bağlantı Sapl.	1
30	Fren Çene Mili	2

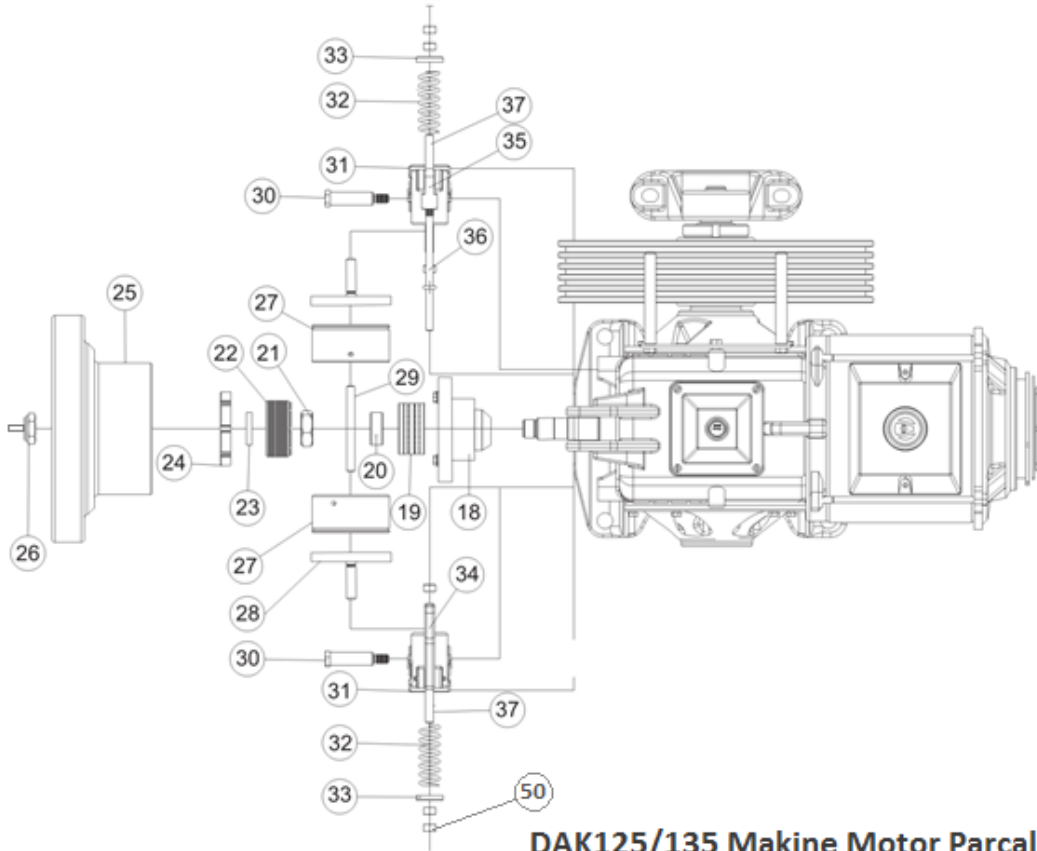

DAK125/135 Makine Motor Parçaları

No	PARÇA	Adet
31	Fren çenesi	2
32	Fren Yayı	2
33	Fren Yayı Merk.Pulu	2
34	Fren Kolu	1
35	Fren Kol.Ayar Gövdesi	1
36	Fren Mek.Kol Saplama	1
37	Fren Çene Saplaması	2
38	Ön Yatak	1
39	Keçe 50x35x8	1
40	Sonsuz Vida	1
41	Kama	2
42	Rotor	1
43	Stator	1
44	Termostat Tutucu	1

No	PARÇA	Adet
45	Klemens kutusu Bloğu	1
46	Klemens Rayı	1
47	Klemens	10
48	Klemens Kutusu Kapağı	1
49	Dış Segman Ø52	1
50	Somun M12	4
51	Fan Motoru	1
52	Motor Kapağı	1
53	Panjur	1
54	Motor kapak Saplaması	4
55	Yağ Tapası	1
56	Makine Üst Kapak	1
57	Yağ Gösterge Tapası	1
58	Yağ Tahliye Tapası	1

9.4. DAK170 Machine/Motor

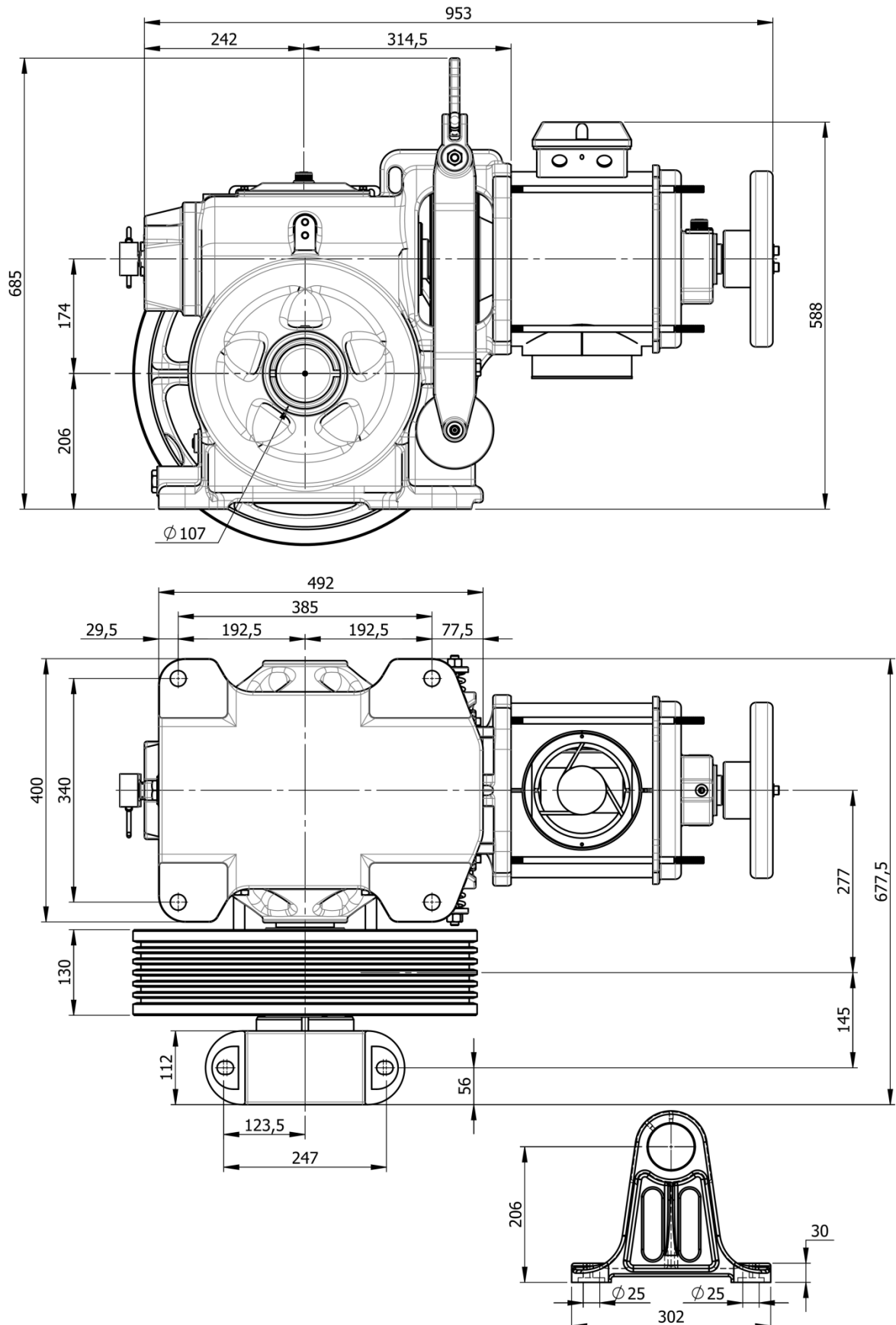

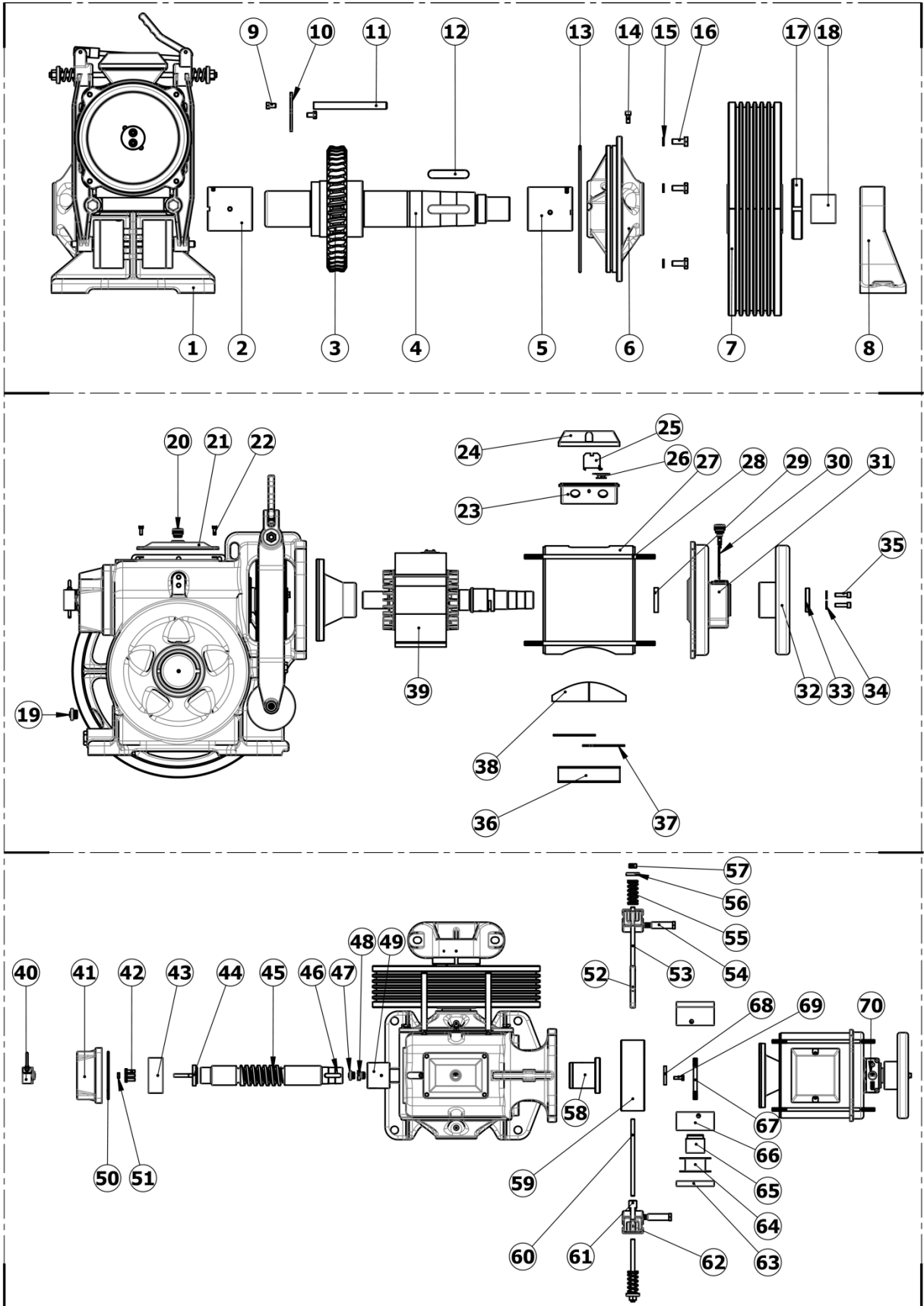

No	PARÇA	Adet	No	PARÇA	Adet
1	Makine gövde	1	36	Fan Kutusu Panjuru	1
2	Ana Mil Burcu Sol	1	37	Fan Bloğu Sacı Yarım Ay	2
3	Sonsuz Dişli	1	38	Fan Kutusu	1
4	Ana Mil	1	39	Stator Montajı	1
5	Ana Mil Burcu Sağ	1	40	Encoder	1
6	Ana Mil Kapağı	1	41	Rulman Kutusu	1
7	Tahrik Kasnağı	1	42	Encoder Bağlantı Civatası	3
8	Makine yan ayak	1	43	Rulman 3310	1
9	Halat Muh. Kolu Bağ. Civ.	2	44	Takometre Bağlantı Aynası	1
10	Halat Muhafaza Kolu Sacı	1	45	Sonsuz Vida	1
11	Halat Muhafaza Kolu	2	46	Kama 12x8x50	1
12	Kama 20x12x100	1	47	Yağ Gösterge Tapası	1
13	O-Ring Ø290x5	1	48	Yağ Tahliye Tapası	1
14	Ana Mil Bur. Sabit.Civata.	2	49	Arka Yatak Burcu	1
15	Ana Mil Kapağı Bağ. Pulu	2	50	O-ring Ø135x5	1
16	Ana Mil Kapağı Bağ. Civ.	5	51	Keçe Ø16xØ10x4	1
17	Tahrik Kasnağı Kont.Som	1	52	Fren Kolu	1
18	Yan Ayak Burcu	1	53	Fren Çene Saplaması	1
19	Yağ Gösterge Tapası	1	54	Fren Çene Pimi	2
20	Yağ Tapası	1	55	Fren Yayı	2
21	Makine Üst Kapak	1	56	Fren Yayı Merkez. Pulu	2
22	Makine Üst Kapak Bağ.Civ	1	57	Fren Yayı Bağlantı Somunu	2
23	Klemens Kutusu Bloğu	1	58	Ön Yatak	1
24	Klemens Kutusu Kapak	1	59	Vida Kaplini	4
25	Klemens	12	60	Fren Mek. Kol Saplaması	1
26	Termostat Tutucu	1	61	Fren Mek. Kol Saplaması Bağl.	1
27	Stator Gövde Sacı	1	62	Fren Çenesi	2
28	Motor Saplaması	4	63	Fren Aynası	2
29	Keçe (50x72x8/45x60x10)	1	64	Fren Bobin Makarası	2
30	Yağ Gösterge Çubuğu	1	65	Fren Nüvesi	2
31	Motor Kapağı	1	66	Fren Kutusu Bloğu	2
32	Volan	1	67	Fren Karkas Saplaması	1
33	Volan Pulu	1	68	Vida Kaplini Pulu	1
34	Volan Pulu Sıkma Civ.Pul	2	69	Vida Kaplini Pulu Civatası	3
35	Volan Pulu Sıkma Civ.	1	70	Yağ Tapası	1

9.5. DAK190 Machine/Motor

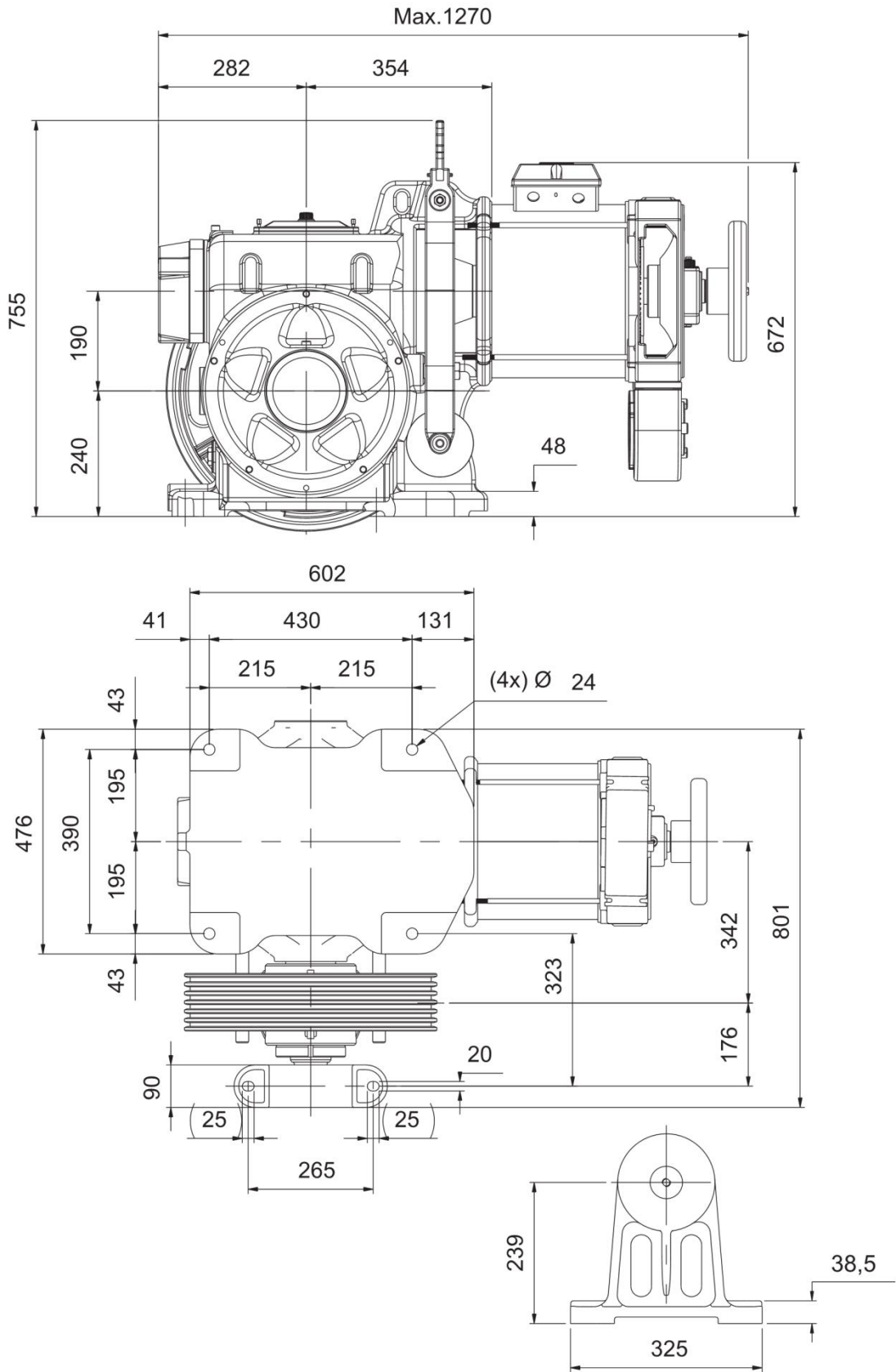

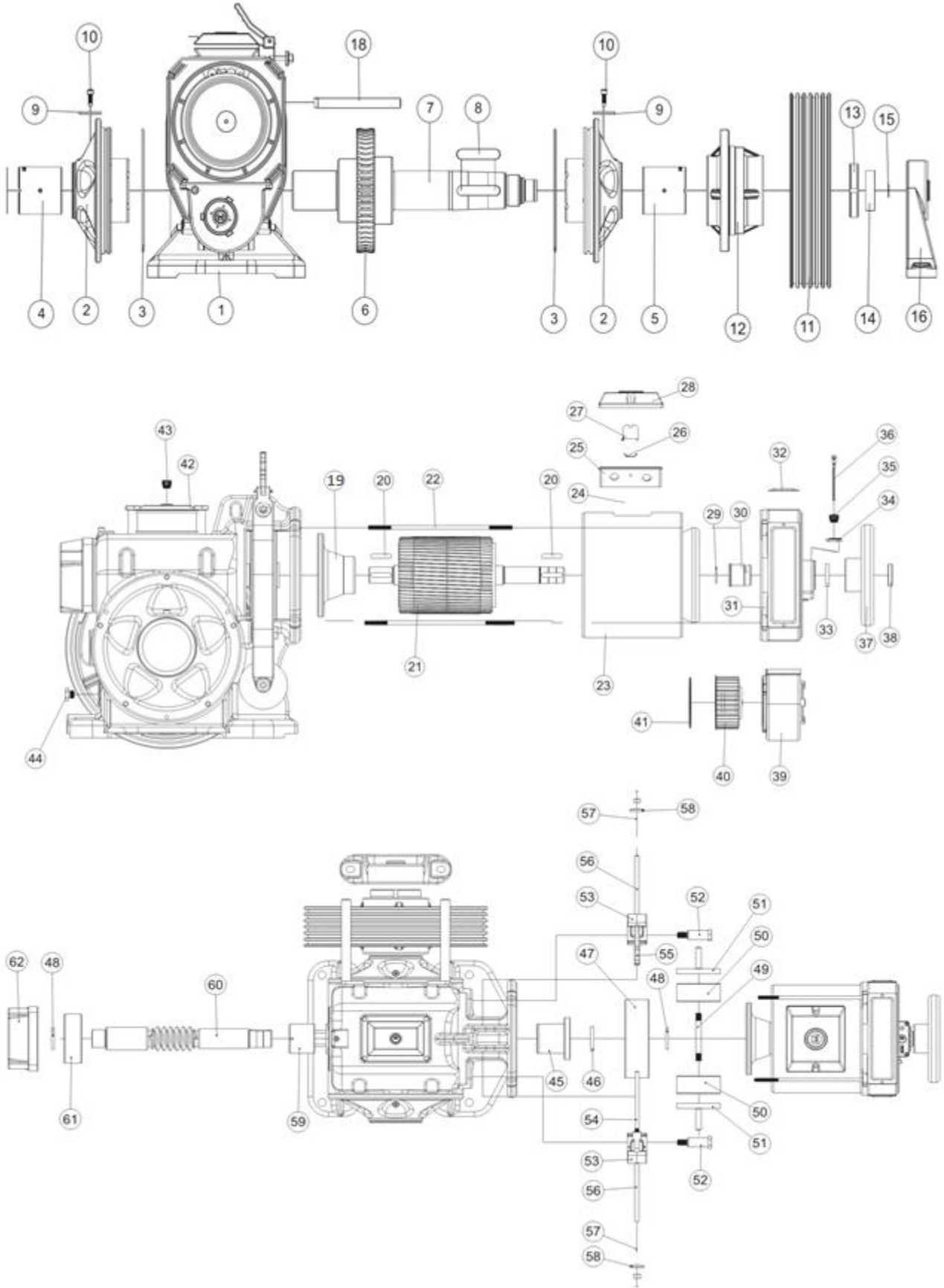

No	PARÇA	Adet
1	Makine Gövde	1
2	Anamil Kapağı	2
3	O-ring Ø316x7	2
4	Anamil Burcu (Sol)	1
5	Anamil Burcu (Sağ)	1
6	Sonsuz Dişli	1
7	Anamil	1
8	Kama 28x16x130	1
9	Ø8 pul	2
10	Anamil bur.sab.civatası	2
11	Tahrik Kasnağı	1
12	Kas. Göb.(göb.kas.için)	1
13	Tah.kas.kont.somunu	1
14	Yan Ayak Burcu	1
15	Setiskur	1
16	Makine yan ayak	1
17	Anamil kapak tapası	1
18	Halat muhafaza kolu	2
19	Motor kaplini	1
20	Kama 12x8x50	1
21	Rotor montaj grubu	1
22	Motor saplaması	4
23	Stator montaj grubu	1
24	Termostat tutucu	1
25	Klemens kutusu bloğu	1
26	Klemens rayı	1
27	Klemens	12
28	Klemens kutusu kapak	1
29	Keçe Ø72xØ50x8	1
30	Motor kapak burcu	1
31	Motor kapağı	1

No	PARÇA	Adet
32	Motor kapak panjuru	3
33	Keçe Ø60xØ45x10	1
34	Motor yağ kapağı	1
35	Yağ tapası	1
36	Yağ gösterge çubuğu	1
37	Volan	1
38	Volan pulu	1
39	Fan kutusu	1
40	Fan motoru	1
41	Fan kutusu panjuru	1
42	Makine üst kapak	1
43	Yağ tapası	1
44	Yağ tahliye tapası	1
45	Ön yatak	1
46	Keçe Ø74xØ60x10	1
47	Vida kaplini	1
48	Vida kaplin pulu	4
49	Fren bağlantı saplaması	1
50	Fren kutusu bloğu	2
51	Fren aynası	2
52	Fren çene pimi	2
53	Fren çenesi	2
54	Fren mek.kol saplaması	1
55	Fren kolu	1
56	Fren çene saplaması	2
57	Fren yayı	2
58	Fren yayı merkez.pulu	2
59	Arka yatak burcu	1
60	Sonsuz vida	1
61	Rulman 3311	1
62	Rulman kutusu	1

10. Label Information

There are two different labels on both machine and motor. These labels have importance for product follow-up machine and motor, to provide better services and to define the machine/motor group.

10.1. Machine Label

AKAR® AKAR ASANSÖR MOTOR MAKİNA SANAYİ LTD. ŞTİ.		Araçtepe Mevkii Sanayi ve Depolama Alanı 5006 Sok. No:18 Selimpaşa/Silivri/İSTANBUL Tel.: +90 212 723 86 78 (Pbx) Faks: +90 212 723 86 80		TSE
DIŞLİLİ ASANSÖR TAHRİK MAKİNASI/GEARED ELEVATOR TRACTION MACHINE				
Tipi Type	<input type="text"/>	Seri No Serial No	<input type="text"/>	
Üretim Yılı Prod. Date	<input type="text"/>	Kapasite Load/Speed	<input type="text"/>	
Ağırlık Weight	<input type="text"/>	Askı Suspension	<input type="text"/>	
Tahvil Oranı Reduction Ratio	<input type="text"/>	www.akarasansor.com		
TÜRKİYE'de Üretilmiştir			Made in TURKEY	

On the label taking place on the machine, type of the machine, chassis number, production year and safe load it can bear and speed amount are appear.

10.1. Motor Label

AKAR® AKAR ASANSÖR MOTOR MAKİNA SANAYİ LTD. ŞTİ.		Selimpaşa Mah. 5006 Sok. No:18 Selimpaşa/Silivri/İSTANBUL Tel.: +90 212 723 86 78 (Pbx) Faks: +90 212 723 86 80		CE	TSE
Motor No.	<input type="text"/>	Güç (P _n) Power (P _n)	<input type="text"/>	PS	<input type="text"/>
Tip Type	<input type="text"/>	Devir (n) Revolution (n)	<input type="text"/>		d/d
Gerilim (U _n) Voltage (U _n)	<input type="text"/>	Yük Akım (I _{load}) Load Current (I _{load})	<input type="text"/>		A
St/h	<input type="text"/>	Moment (M _n)	<input type="text"/>		Nm
Frekans (F _n) Frequency (F _n)	<input type="text"/>	Kutup Sayısı Pole Number	<input type="text"/>		
Cos φ	<input type="text"/>	İzol. Sınıfı Iso. Class	<input type="text"/>	F	
Üretim Yılı Prod. Date	<input type="text"/>	Kor. Sınıfı Pro Class	<input type="text"/>		
TÜRKİYE'de Üretilmiştir		www.akarasansor.com		Made in TURKEY	

On the label taking place on the motor, motor serial number, motor type, motor power and motor characteristics information is given.

In case of encountering any problem relevant to machine / motor group, information on both of the labels have importance to follow-up product and provide better quality service.

11. Chassis Types Recommended for Machine / Motor

Before the installation control the surface balance of the chassis platform. During installation, assuredly feed the bottoms of chassis with support blocks preventing vibration. Affix the Machine fixing bolts diagonally.

There are two chassis group recommended for Machine/Motor group. These are;

1. Chassis type placed onto concrete basement
2. Steel construction chassis type (sides supported)

11.1. Sample of Chassis Placed on Concrete basement

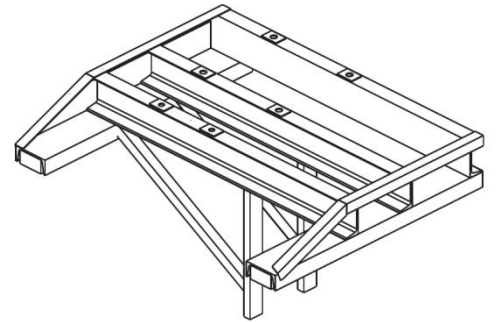
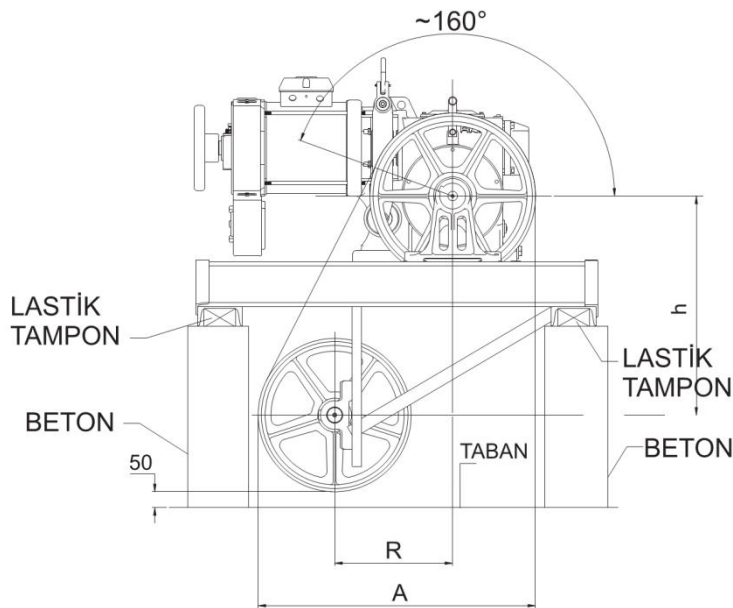

11.2. Steel Construction Used Chassis Sample

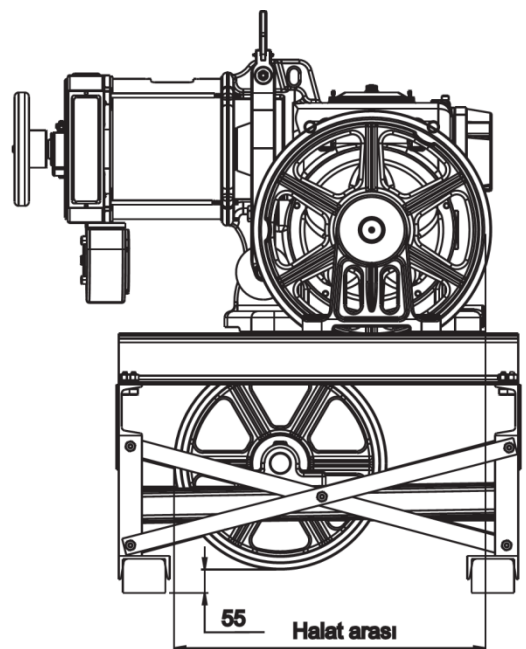
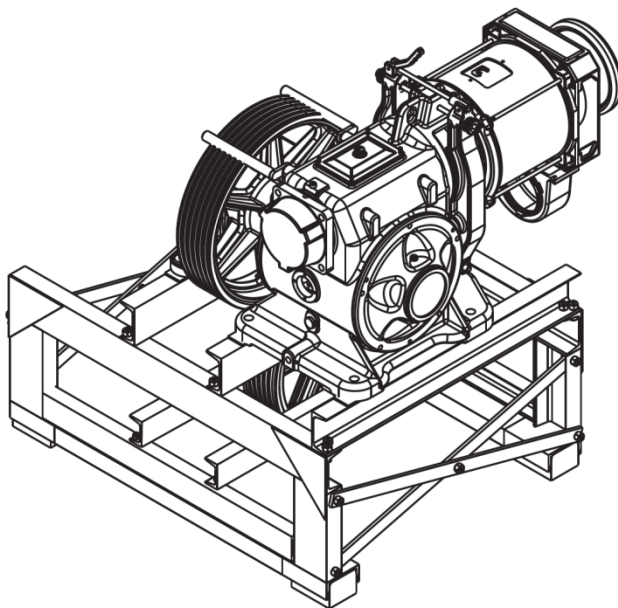

12. Support Bearing Installation

1. Be careful for the heights of the surface where support bearing is placed and surface where machine placed are even. In case of surfaces machine and support bearing placed are not even, it is possible to happen clamping at machine and in this case the expected comfort could not be obtained.

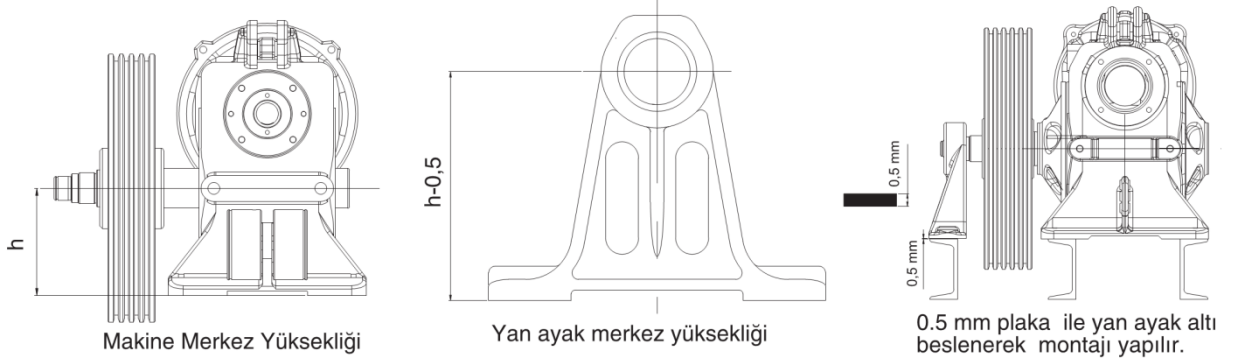

2. Center of support bearing is -0,50mm lower than machine center. During installation, mount by feeding the bottom of support bearing with 0,50mm metal sheet. Otherwise, bearing and primary shaft will operate tightened.
3. Before tightening the machine bolts and while support bearing is unoccupied, ensure that the traction sheave is easily rotating by releasing the brake arm.
4. Tighten the fixing bolts present on machine and support bearing diagonally and check puller rotating at the same ease.